

IEEE Std C37.23™-2003
(Revision of
IEEE Std C37.23-1987)

C37.23™

IEEE Standard for Metal-Enclosed Bus

IEEE Power Engineering Society

Sponsored by the
Switchgear Committee



Published by
The Institute of Electrical and Electronics Engineers, Inc.
3 Park Avenue, New York, NY 10016-5997, USA

26 April 2004

Print: SH95180
PDF: SS95180

IEEE Standards

*Recognized as an
American National Standard (ANSI)*

IEEE Std C37.23™-2003
(Revision of
IEEE Std C37.23-1987)

IEEE Standard for Metal-Enclosed Bus

Sponsor

Switchgear Committee
of the
IEEE Power Engineering Society

Approved 11 September 2003

IEEE-SA Standards Board

Approved 29 January 2004

American National Standards Institute

Abstract: Metal-enclosed (ME) bus assemblies for indoor and outdoor use are covered in this standard. The types of assemblies covered are nonsegregated-phase bus, segregated-phase bus, and isolated-phase bus. Rated maximum voltages of ac ME bus assemblies range from 0.635 kV through 38 kV with continuous current ratings of 600 A through 26 000 A for self-cooled ratings and up to 40 000 A and above for force-cooled ratings. Rated maximum voltage levels of dc bus assemblies range from 300 V through 3200 V with continuous current ratings of 600 A through 12 000 A. Service conditions, ratings, temperature limitations and classification of insulating materials, insulation (dielectric) withstand voltage requirements, test procedures, and application are discussed. A guide for calculating losses in isolated-phase bus is included.

Keywords: isolated-phase bus, metal-enclosed bus, nonsegregated-phase bus, segregated-phase bus

The Institute of Electrical and Electronics Engineers, Inc.
3 Park Avenue, New York, NY 10016-5997, USA

Copyright © 2004 by the Institute of Electrical and Electronics Engineers, Inc.
All rights reserved. Published 26 April 2004. Printed in the United States of America.

National Electrical Code and NEC are both registered trademarks of the National Fire Protection Association, Inc.

IEEE is a registered trademark in the U.S. Patent & Trademark Office, owned by the Institute of Electrical and Electronics Engineers, Incorporated.

Print: ISBN 0-7381-3834-7 SH95180
PDF: ISBN 0-7381-3835-5 SS95180

No part of this publication may be reproduced in any form, in an electronic retrieval system or otherwise, without the prior written permission of the publisher.

IEEE Standards documents are developed within the IEEE Societies and the Standards Coordinating Committees of the IEEE Standards Association (IEEE-SA) Standards Board. The IEEE develops its standards through a consensus development process, approved by the American National Standards Institute, which brings together volunteers representing varied viewpoints and interests to achieve the final product. Volunteers are not necessarily members of the Institute and serve without compensation. While the IEEE administers the process and establishes rules to promote fairness in the consensus development process, the IEEE does not independently evaluate, test, or verify the accuracy of any of the information contained in its standards.

Use of an IEEE Standard is wholly voluntary. The IEEE disclaims liability for any personal injury, property or other damage, of any nature whatsoever, whether special, indirect, consequential, or compensatory, directly or indirectly resulting from the publication, use of, or reliance upon this, or any other IEEE Standard document.

The IEEE does not warrant or represent the accuracy or content of the material contained herein, and expressly disclaims any express or implied warranty, including any implied warranty of merchantability or fitness for a specific purpose, or that the use of the material contained herein is free from patent infringement. IEEE Standards documents are supplied “**AS IS.**”

The existence of an IEEE Standard does not imply that there are no other ways to produce, test, measure, purchase, market, or provide other goods and services related to the scope of the IEEE Standard. Furthermore, the viewpoint expressed at the time a standard is approved and issued is subject to change brought about through developments in the state of the art and comments received from users of the standard. Every IEEE Standard is subjected to review at least every five years for revision or reaffirmation. When a document is more than five years old and has not been reaffirmed, it is reasonable to conclude that its contents, although still of some value, do not wholly reflect the present state of the art. Users are cautioned to check to determine that they have the latest edition of any IEEE Standard.

In publishing and making this document available, the IEEE is not suggesting or rendering professional or other services for, or on behalf of, any person or entity. Nor is the IEEE undertaking to perform any duty owed by any other person or entity to another. Any person utilizing this, and any other IEEE Standards document, should rely upon the advice of a competent professional in determining the exercise of reasonable care in any given circumstances.

Interpretations: Occasionally questions may arise regarding the meaning of portions of standards as they relate to specific applications. When the need for interpretations is brought to the attention of IEEE, the Institute will initiate action to prepare appropriate responses. Since IEEE Standards represent a consensus of concerned interests, it is important to ensure that any interpretation has also received the concurrence of a balance of interests. For this reason, IEEE and the members of its societies and Standards Coordinating Committees are not able to provide an instant response to interpretation requests except in those cases where the matter has previously received formal consideration. At lectures, symposia, seminars, or educational courses, an individual presenting information on IEEE standards shall make it clear that his or her views should be considered the personal views of that individual rather than the formal position, explanation, or interpretation of the IEEE.

Comments for revision of IEEE Standards are welcome from any interested party, regardless of membership affiliation with IEEE. Suggestions for changes in documents should be in the form of a proposed change of text, together with appropriate supporting comments. Comments on standards and requests for interpretations should be addressed to:

Secretary, IEEE-SA Standards Board
445 Hoes Lane
P.O. Box 1331
Piscataway, NJ 08855-1331
USA

Note: Attention is called to the possibility that implementation of this standard may require use of subject matter covered by patent rights. By publication of this standard, no position is taken with respect to the existence or validity of any patent rights in connection therewith. The IEEE shall not be responsible for identifying patents for which a license may be required by an IEEE standard or for conducting inquiries into the legal validity or scope of those patents that are brought to its attention.

Authorization to photocopy portions of any individual standard for internal or personal use is granted by the Institute of Electrical and Electronics Engineers, Inc., provided that the appropriate fee is paid to Copyright Clearance Center. To arrange for payment of licensing fee, please contact Copyright Clearance Center, Customer Service, 222 Rosewood Drive, Danvers, MA 01923 USA; +1 978 750 8400. Permission to photocopy portions of any individual standard for educational classroom use can also be obtained through the Copyright Clearance Center.

Introduction

(This introduction is not a part of IEEE Std C37.23-2003, IEEE Standard for Metal-Enclosed Bus.)

This standard has been revised to reflect needed technical changes that have been suggested since the last revision to IEEE Std C37.23 -2003 was published in 1987. The major revision is the removal of reference to metal-enclosed bus with flexible conductors. Other significant changes are as follows:

- A move toward uniformity with related standards by adopting the wording contained therein
- Expansion of the application guide for ME bus
- Inclusion of switches or links for station-service transformers
- Expansion and clarification of the tables in keeping with updates made in other standards

It is also noted that the altitude correction factors listed in Table 6 of this standard are under review by an IEEE Switchgear Committee Working Group. The values included in this document are for reference until the Working Group releases the new values, after which time the new values may be incorporated into this standard.

This standard includes only the requirements for ME bus. These requirements were previously a part of IEEE Std C37.20™-1969, IEEE Standard for Switchgear Assemblies Including Metal-Enclosed Bus (1974, consolidated edition). Other types of equipment previously included in IEEE Std C37.20-1969 are incorporated in separate publications.

IEEE Std C37.20-1969 had for many years covered all switchgear assemblies, including metal-enclosed bus. Standards committees of the IEEE Switchgear Assemblies Subcommittee and the NEMA Power Switchgear Assemblies Technical Committee recommended that the standard be further developed and, where appropriate, that the various sections be identified with their own standards. This approach also coordinates with the conformance test procedure standards.

The IEEE Switchgear Assemblies Subcommittee was responsible for this revision.

This publication is one of a series covering switchgear assemblies as follows:

IEEE Std C37.20.1™-2002	IEEE Standard for Metal-Enclosed Low-Voltage Power Circuit Breaker Switchgear [B14] ^a
IEEE Std C37.20.2™-1999	IEEE Standard for Metal-Clad Switchgear
IEEE Std C37.20.3™-2001	IEEE Standard for Metal-Enclosed Interrupter Switchgear [B15]
IEEE Std C37.20.4™-2001	IEEE Standard for Indoor AC Switches (1 kV–38 kV) for Use in Metal Enclosed Switchgear [B16]
IEEE Std C37.21™-1985	IEEE Standard for Control Switchboards
IEEE Std C37.23-2003	IEEE Standard for Metal-Enclosed Bus
IEEE Std C37.24™-1986	IEEE Guide for Evaluating the Effect of Solar Radiation on Outdoor Metal-Enclosed Switchgear (Reaff 1998)

^aThe numbers in brackets correspond to those in the bibliography in Annex B.

Notice to Users

Errata

Errata, if any, for this and all other standards can be accessed at the following URL: <http://standards.ieee.org/reading/ieee/updates/errata/index.html>. Users are encouraged to check this URL for errata periodically.

Interpretations

Current interpretations can be accessed at the following URL: <http://standards.ieee.org/reading/ieee/interp/index.html>.

Participants

At the time this standard was completed, the IEEE Switchgear Assemblies Subcommittee Working Group had the following membership:

R. K. Iyer, *Co-Chair*
Edward A. Peters, *Co-Chair*
Michael Wactor, *Secretary*

Ted A. Burse
Louis Doucet
Doug J. Edwards
S. S. (Dave) Gohil

Frank W. Mayle
Anne F. Morgan
George R. Nourse

T. W. Olsen
Ibrahim Shteyh
James E. Smith
Chand Z. Tailor

The Switchgear Assemblies Subcommittee of the IEEE Switchgear Committee that reviewed and approved this standard had the following membership:

Ted A. Burse, *Chair*

S. C. Atkinson
Charles J. Ball
E. R. Byron
J. J. Dravis
L. W. Gaussa
R. K. Iyer
R. P. Jackson
Jerry M. Jerabek

Ward E. Laubach
David J. Lemmerman
W. McCowen
W. C. McKay
Paul Notarian
George R. Nourse
T. W. Olsen

G. O. Perkins
Edward A. Peters
R. J. Puckett
Gerald Sakats
J. C. Scott
Stanton H. Telander
J. H. Ugo
Michael Wactor

The following members of the balloting committee voted on this standard. Balloters may have voted for approval, disapproval, or abstention.

Stan J. Arnot	Albert Livshitz	Ralph Philbrook, III
Charles J. Ball	Gregory Luri	Jackson Richard
Ted A. Burse	Keith Malmedal	Joe Rostron
Tommy Cooper	Frank W. Mayle	James Ruggieri
Ronald Daubert	Deepak Mazumdar	Gerald Sakats
Louis Doucet	Kenneth McClenahan	Ewald Schweiger
Doug J. Edwards	Nigel McQuin	Devki Sharma
Gary Engmann	John Merando	Jordan Shikoski
S. S. (Dave) Gohil	Gary Michel	Ibrahim Shteyh
Manuel Gonzalez	Daleep C. Mohla	H. Jin Sim
Keith Gray	Alec Monroe	David Singleton
Randall Groves	Georges Montillet	James E. Smith
Erik Guillot	Anne F. Morgan	Rao Sunkara
Harold L. Hess	Karl Mortensen	Chand Z. Tailor
Edward Horgan, Jr.	Arun Narang	Stanton H. Telander
Jerry M. Jerabek	Paul Notarian	Shanmugan Thamilarasan
Thomas LaRose	George R. Nourse	Alan Traut
Ward E. Laubach	T. W. Olsen	Gerald Vaughn
John Leach	Miklos Orosz	Michael Wactor
David J. Lemmerman	Edward A. Peters	Charles Wagner
George N. Lester		James Wilson

When the IEEE-SA Standards Board approved this standard on 11 September 2003, it had the following membership:

Don Wright, *Chair*
Howard M. Frazier, *Vice Chair*
Judith Gorman, *Secretary*

H. Stephen Berger	Donald N. Heirman	Daleep C. Mohla
Joseph A. Bruder	Laura Hitchcock	William J. Moylan
Bob Davis	Richard H. Hulett	Paul Nikolich
Richard DeBlasio	Anant Kumar Jain	Gary S. Robinson
Julian Forster*	Lowell G. Johnson	Malcolm V. Thaden
Toshio Fukuda	Joseph L. Koepfinger*	Geoffrey O. Thompson
Arnold M. Greenspan	Tom McGean	Doug Topping
Raymond Hapeman	Steve M. Mills	Howard L. Wolfman

*Member Emeritus

Also included are the following nonvoting IEEE-SA Standards Board liaisons:

Alan Cookson, *NIST Representative*
Satish K. Aggarwal, *NRC Representative*

Savoula Amanatidis
IEEE Standards Managing Editor

Contents

1.	Scope.....	1
2.	References.....	1
3.	Definitions.....	2
4.	Service conditions.....	4
5.	Ratings	4
	5.1 General.....	4
	5.2 Voltage and insulation levels.....	5
	5.3 Rated power frequency	7
	5.4 Rated current.....	7
6.	Tests.....	10
	6.1 General.....	10
	6.2 Design tests.....	12
	6.3 Production tests.....	17
	6.4 Field tests	18
7.	Construction.....	18
	7.1 Materials and finish.....	18
	7.2 Grounding	19
	7.3 Adjacent and supporting structure	19
	7.4 Ventilation.....	19
	7.5 Force-cooled	19
	7.6 Vapor barriers	21
	7.7 Fire barriers.....	21
	7.8 Insulating materials for covering buses and connections	21
	7.9 Terminations and flexible connections	21
	7.10 Switches or links for station-service transformers.....	21
	7.11 Secondary wiring	21
8.	Miscellaneous accessories	22
9.	Application guide for ME bus.....	23
	9.1 Ambient air temperature above 40 °C.....	23
	9.2 Ambient air temperature below –30 °C	23
	9.3 Application at unusual altitudes.....	23
	9.4 Other conditions that may affect design and application.....	23
	9.5 Modification of equipment for unusual environment	24
	Annex A (informative) Guide for calculating losses in isolated-phase bus.....	27
	Annex B (informative) Bibliography.....	47

IEEE Standard for Metal-Enclosed Bus

1. Scope

This standard covers assemblies of metal-enclosed (ME) conductors along with associated interconnections, enclosures, and supporting structures. When switches and disconnecting links are included, they shall conform to this standard.

This standard is concerned with performance characteristics of enclosed, rather than open, indoor and outdoor conductor assemblies with rated maximum operating voltages through 38 kV. While this standard does cover 600 V bus assemblies, it does not pertain to UL 857-2001 type busways and associated fittings, nor does it pertain to ME bus assemblies utilizing cables as the primary conductors.

2. References

When the following publications are superseded by a revision approved by the issuing authority, the revision shall apply.

ANSI C29.1-1988 (Reaff 2002), American National Standard Test Methods for Electrical Power Insulators.¹

ASTM D229-2001, Standard Test Methods for Rigid Sheet and Plate Materials Used for Electrical Insulation.²

ASTM D1535-2001, Standard Practice for Specifying Color by the Munsell System.

ASTM G21-1996 (Reaff 2002), Standard Practice for Determining Resistance of Synthetic Polymeric Materials to Fungi.

IEEE Std 1TM-2000, IEEE Recommended Practice—Principles for Temperature Limits in the Rating of Electrical Equipment and for the Evaluation of Electrical Insulation.^{3,4}

¹ANSI publications are available from the Sales Department, American National Standards Institute, 25 West 43rd Street, 4th Floor, New York, NY 10036, USA (<http://www.ansi.org>).

²ASTM publications are available from the American Society for Testing and Materials, 100 Barr Harbor Drive, West Conshohocken, PA 19428-2959, USA (<http://www.astm.org>).

³The IEEE standards or products referred to in Clause 2 are trademarks owned by the Institute of Electrical and Electronics Engineers, Incorporated.

⁴IEEE publications are available from the Institute of Electrical and Electronics Engineers, Inc., 445 Hoes Lane, P.O. 1331, Piscataway, NJ 08855-1331, USA (<http://standards.ieee.org>).

IEEE Std 4TM-1995, IEEE Standard Techniques for High-Voltage Testing.

IEEE Std 4aTM-2001, Amendment to IEEE Standard Techniques for High-Voltage Testing.

IEEE Std 344TM-1987 (Reaff 1993), IEEE Recommended Practice for Seismic Qualification of Class 1E Equipment for Nuclear Power Generating Stations.

IEEE Std C37.20.2TM -1999, IEEE Standard for Metal-Clad Switchgear.

IEEE Std C37.24TM-1986 (Reaff 1998), IEEE Guide for Evaluating the Effect of Solar Radiation on Outdoor Metal-Enclosed Switchgear.

IEEE Std C37.81TM-1989 (Reaff 1994), IEEE Guide for Seismic Qualification of Class 1E Metal-Enclosed Power Switchgear Assemblies.

IEEE Std C37.100TM-1992 (Reaff 2001), IEEE Standard Definitions for Power Switchgear.

NEMA WC 70-1999/ICEA S-95-658-1999, Non-shielded Power Cable Rated 2000 V or Less for the Distribution of Electrical Energy.^{5,6}

NFPA 70-2002, National Electrical Code[®] (NEC[®]).⁷

UL 857-2001, Busways.⁸

3. Definitions

The definitions of terms contained in this standard, or in other standards referred to in this standard, are not intended to embrace all legitimate meanings of the terms. They are applicable only to the subject treated in this standard.

If a term is not defined in this standard, the definition in IEEE Std C37.100-1992 applies. An asterisk (*) following a definition indicates that the definition in this standard is not contained in IEEE Std C37.100-1992; while a (+) indicates the definition differs from that in IEEE Std C37.100-1992.

3.1 ambient air temperature: The temperature of the surrounding air that comes in contact with equipment.

NOTE—Ambient air temperature, as applied to ME bus assemblies, is the average temperature of the surrounding air that comes in contact with the enclosure.

3.2 design tests: Those tests made to determine the adequacy of a particular type, style, or model of ME bus or its component parts to meet its assigned ratings and to operate satisfactorily under normal service conditions or under special conditions, if specified.

⁵NEMA publications are available from Global Engineering Documents, 15 Inverness Way East, Englewood, CO 80112, USA (<http://global.ihs.com/>).

⁶ICEA publications are available from ICEA, P.O. Box 20048, Minneapolis, MN 55420, USA (<http://www.icea.org/>).

⁷NFPA publications are available from Publications Sales, National Fire Protection Association, 1 Batterymarch Park, P.O. Box 9101, Quincy, MA 02269-9101, USA (<http://www.nfpa.org>).

⁸UL standards are available from Global Engineering Documents, 15 Inverness Way East, Englewood, CO 80112, USA (<http://global.ihs.com/>).

NOTE—Design tests are made only on representative apparatus to substantiate the ratings assigned to all other apparatus of basically the same design. These tests are not intended to be used as a part of normal production. The applicable portion of these design tests may also be used to evaluate modifications of a previous design and to assure that performance has not been adversely affected. Test data from previous similar designs may be used for current designs, where appropriate.

3.3 enclosure: A surrounding case or housing used to protect the contained conductor and prevent personnel from accidentally contacting live parts

3.3.1 drip-proof enclosure: An enclosure, usually for indoor application, so constructed or protected that falling drops of liquid or solid particles that strike the enclosure at any angle not greater than 15 degrees from the vertical shall not interfere with the successful operation of ME bus.*

3.3.2 nonventilated enclosure: An enclosure so constructed as to provide no intentional circulation of external air through the enclosure.

3.3.3 ventilated enclosure: An enclosure provided with means to permit circulation of sufficient air to remove an excess of heat, fumes, or vapors.

NOTE—For outdoor applications, ventilating openings or louvers are usually filtered, screened, or restricted to limit the entrance of dust, dirt, rain, or other foreign objects.

3.4 field tests: Tests made after the assembly has been installed at its place of utilization.

3.5 metal-enclosed (ME) (as applied to ME bus): Surrounded by a metal case or housing, with provisions for grounding.*

3.6 ME bus: An assembly of conductors with associated connection joints and insulating supports within a grounded metal enclosure. The conductors shall be rigid bus bar, but may include flexible connectors.

3.7 production tests (ME bus): Test made for quality control by the manufacturer on every device or representative samples, or on parts or materials required to verify during production that the product meets the design specifications and applicable standards.

NOTE—Production tests are sometimes called routine tests.

3.8 support components: These add additional strength and rigidity or both to the bus enclosure and are basic subassemblies of the enclosure.

3.9 termination (terminal chamber): A metal enclosure that contains all necessary mechanical and electrical items to complete the connections to other equipment.

3.10 types of ME bus assemblies: In general, three basic types of construction are used: nonsegregated-phase, segregated-phase, and isolated-phase.

- a) *Nonsegregated-phase bus.* One in which all phase conductors are in a common metal enclosure without barriers between the phases.

When associated with metal-clad switchgear, the phase conductors of a non-insulated bus assembly entering the switchgear assembly and connecting to the switchgear bus shall be covered with insulating material equivalent to the switchgear insulation system.

- b) *Segregated-phase bus.* One in which all phase conductors are in a common metal enclosure but are segregated by metal barriers between phases.
- c) *Isolated-phase bus.* One in which each phase conductor is enclosed by an individual metal housing separated from the adjacent conductor housing by an air space.

The bus may be self-cooled or may be force-cooled by means of circulating a gas or liquid.

NOTE—See Figure 1.

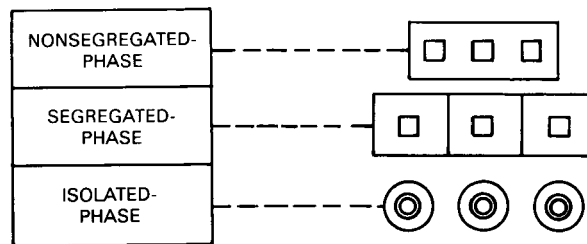

Figure 1—Types of bus assemblies

4. Service conditions

American National Standards for the design and performance of ME bus assemblies are based on usual service conditions as described in the following list. The selection of equipment for a particular application can be based on the construction and ratings as defined in this standard, provided that these usual service conditions exist.

- a) Ambient air temperature is within the limits of $-30\text{ }^{\circ}\text{C}$ and $+40\text{ }^{\circ}\text{C}$.
- b) The altitude of the installation does not exceed the value for which the voltage and current correction factors (shown in Table 12) are equal to 1.00.
- c) The effect of solar radiation is not significant and can be neglected (the principles stated in IEEE Std C37.24-1986 may be used for guidance).
- d) Unusual service conditions, such as outlined in Clause 9, do not prevail. The user should review Clause 9 for unusual service conditions and other considerations when preparing specifications for ME bus because these unusual conditions impact the equipment design.

5. Ratings

5.1 General

The ratings of ME bus are designations of operating limits under specified conditions of ambient temperature, temperature rise, etc.

ME bus shall have the following ratings:

- a) Rated maximum voltage
- b) Rated power frequency
- c) Rated insulation levels
- d) Rated continuous current
- e) Rated short-time withstand current
- f) Rated momentary withstand current

For force-cooled bus, both the force-cooled and the self-cooled continuous-current rating for the same temperature rise shall be given.

The designated ratings in this standard are preferred but are not considered to be restrictive.

5.2 Voltage and insulation levels

5.2.1 Rated maximum voltage

The rated maximum voltage of ME bus is the highest rms voltage (for ac ME bus) or dc voltage (for dc bus) for which the equipment is designed, and is the upper limit for operation.

5.2.2 Rated insulation levels

The rated insulation levels of ME bus shall consist of the following two items:

- a) Power frequency withstand voltage
- b) Lightning impulse withstand voltage

5.2.3 Voltages and insulation levels

The preferred rated maximum voltages and corresponding insulation levels for ME bus are listed in Table 1, Table 2, and Table 3. (For dc ratings, refer to Table 4.)

Table 1—Isolated-phase bus—preferred voltage ratings and insulation level

Rated maximum voltage (kV rms)	Insulation level			
	Power frequency withstand (kV rms)		DC withstand dry ^b (kV)	Lightning impulse withstand (kV peak)
	Dry (1 min)	Dew ^a (10 s)		
15.5	50	50	—	110
27.0	60	60	—	125
38.0	80	70	—	150

NOTE—For field test values see 6.4.2.

^aDew tests are not required when condensation control is utilized as required for the specified application conditions, or when insulators used have been previously qualified in accordance with ANSI C29.1-1988 dew tests. When required, dew withstand voltage tests shall be made in accordance with ANSI C29.1-1988.

^bThe presence of “dc withstand dry” does not imply any requirement for a dc withstand test on either ac or dc equipment. This column is given as a reference only for those using dc tests and represents values believed to be appropriate and approximately equivalent to the corresponding ac power frequency withstand test values specified for each class of bus.

Because of the variable voltage distribution encountered when making dc withstand tests and variances in leakage currents associated with various insulation systems, the manufacturer should be contacted for recommendations before applying dc withstand tests to this equipment.

Table 2—Nonsegregated-phase bus—preferred voltage ratings and insulation level

Rated maximum voltage (kV rms)	Insulation level			
	Power frequency withstand (kV rms)		DC withstand dry ^b (kV)	Lightning impulse withstand (kV peak)
	Dry (1 min)	Dew ^a (10 s)		
0.635	2.2	—	3.1	—
4.760	19	15	27	60
8.250	36	24	50	95
15.000	36	24	50	95
15.500	50	30	—	110
27.000	60	40	—	125
38.000	80	70	—	150

NOTE—For field test values see 6.4.2.

^aDew tests are not required when condensation control is utilized as required for the specified application conditions, or when insulators used have been previously qualified in accordance with ANSI C29.1-1988 dew tests. When required, dew withstand voltage tests shall be made in accordance with ANSI C29.1-1988.

^bThe presence of “dc withstand dry” does not imply any requirement for a dc withstand test on either ac or dc equipment. This column is given as a reference only for those using dc tests and represents values believed to be appropriate and approximately equivalent to the corresponding ac power frequency withstand test values specified for each class of bus.

Because of the variable voltage distribution encountered when making dc withstand tests and variances in leakage currents associated with various insulation systems, the manufacturer should be contacted for recommendations before applying dc withstand tests to this equipment.

Table 3—Segregated-phase bus—preferred voltage ratings and insulation level

Rated maximum voltage (kV rms)	Insulation level			
	Power frequency withstand (kV rms)		DC withstand dry ^b (kV)	Lightning impulse withstand (kV peak)
	Dry (1 min)	Dew ^a (10 s)		
15.5	50	30	—	110
27.0	60	40	—	125
38.0	80	70	—	150

NOTE—For field test values see 6.4.2.

^aDew tests are not required when condensation control is utilized as required for the specified application conditions, or when insulators used have been previously qualified in accordance with ANSI C29.1-1988 dew tests. When required, dew withstand voltage tests shall be made in accordance with ANSI C29.1-1988.

^bThe presence of “dc withstand dry” does not imply any requirement for a dc withstand test on either ac or dc equipment. This column is given as a reference only for those using dc tests and represents values believed to be appropriate and approximately equivalent to the corresponding ac power frequency withstand test values specified for each class of bus.

Because of the variable voltage distribution encountered when making dc withstand tests and variances in leakage currents associated with various insulation systems, the manufacturer should be contacted for recommendations before applying dc withstand tests to this equipment.

Table 4—DC bus duct—preferred voltage ratings and insulation level

Rated maximum voltage (V)	Insulation level	
	DC withstand dry ^a (kV)	Power frequency withstand (kV rms)
300 / 325	3.1	2.4
800	5.9	4.2
1200	6.8	4.8
1600	7.6	5.4
3200	12.4	8.8

NOTE—For field test values see 6.4.2.

^aThe presence of “dc withstand dry” does not imply any requirement for a dc withstand test on either ac or dc equipment. This column is given as a reference only for those using dc tests and represents values believed to be appropriate and approximately equivalent to the corresponding ac power frequency withstand test values specified for each class of bus.

Because of the variable voltage distribution encountered when making dc withstand tests and variances in leakage currents associated with various insulation systems, the manufacturer should be contacted for recommendations before applying dc withstand tests to this equipment.

5.3 Rated power frequency

The rated power frequency of ME bus is the frequency of the circuit for which it is designed. All ac ratings in this standard are based on a rated power frequency of 60 Hz.

5.4 Rated current

5.4.1 Rated continuous current

The rated continuous current of ME bus is the maximum current in rms amperes (for ac ME bus) at rated power frequency or dc amperes (for dc bus), which can be carried continuously by the primary circuit components, including buses and connections, without causing temperatures in excess of specified limits for the following:

- a) Any primary or secondary circuit component
- b) Any insulating medium, or structural or enclosing member

The specified temperature limits applicable to ME bus are given in Table 5 and Table 6. The continuous self-cooled current ratings of ME bus are listed in Table 7 and Table 8.

Table 5—Temperature limits for ME bus

Part of ME bus	Limit of hottest-spot temperature rise (°C)	Limit of hottest-spot total temperature (°C)
Bus conductor		
a) Unplated bus joints	30	70
b) Tin- or silver-surfaced (or equivalent) bolted joints	65 (unless limited by insulation)	105
c) Welded joints	65	105
Enclosures and support structure ^a		
a) For bus conductor rated 65 °C rise	40	80
b) For bus conductor rated 30 °C rise	20	60
Insulation	As limited by material classification (see Table 6)	—
Terminations	Same as conductor and enclosure of bus except when modified by connected equipment bushing. In such cases, maximum temperature rise is to be specified by bus purchaser.	—
Connections to insulated cables		
a) Unplated bolted joints	30	70
b) Tin- or silver-surfaced (or equivalent) bolted joints	45	85

^aWhere enclosure and support structure are inaccessible to an operator in the normal course of his duties, 70 °C rise and 110 °C total temperature are permissible.

Table 6—Temperature limits for insulating materials^a

Class of insulating material	Limit of hottest-spot temperature rise (°C)	Limit of hottest-spot total temperature (°C)
Class 90	50	90
Class 105	65	105
Class 130	90	130
Class 155	115	155
Class 180	140	180
Class 220	180	220
NOTE—For additional information on temperature limits, see IEEE Std 1-2000.		

^aThese temperature limits for insulating materials may not apply to insulation in circuit breakers or other devices. For temperature limits on devices, refer to the appropriate standards for the devices.

Table 7—Isolated-phase bus—preferred continuous self-cooled current ratings (rms amperes)

Current ratings (based on temperature rise shown in Table 5)		
1200	7 000	16 000
2000	8 000	18 000
3000	9 000	20 000
4000	10 000	22 000
5000	12 000	24 000
6000	14 000	—

Table 8—Segregated-phase and nonsegregated-phase bus—preferred continuous self-cooled current ratings (rms amperes)

Rated maximum voltage (kV)					
0.635 ac and all dc	4.76	8.25 and 15	15.5	27	38
600	—	—	—	—	—
1 200	1200	1200	1200	1200	1200
1 600	—	—	—	—	—
2 000	2000	2000	2000	2000	2000
2 500	—	—	2500	2500	2500
3 000	3000	3000	3000	3000	3000
3 200	—	—	3500	—	—
4 000	4000	4000	4000	—	—
—	—	—	4500	—	—
5 000	5000	5000	5000	—	—
—	—	—	5500	—	—
6 000	6000	6000	6000	—	—
8 000	—	—	—	—	—
10 000	—	—	—	—	—
12 000	—	—	—	—	—

5.4.2 Rated momentary withstand current

The rated momentary withstand current of ME bus is the maximum rms total current that it shall be required to withstand. The current shall be the rms value, including the dc component, at the major peak of the maximum cycle as determined from the envelope of the current wave in the maximum offset phase during a test period of at least 10 cycles unless limited to a shorter time by the protective device. Preferred ratings are given in Table 9 and Table 10.

NOTE—The momentary withstand current test is also known as the peak withstand current test for 10 cycles.

For dc bus duct, the rated momentary withstand current shall be the peak instantaneous value at the maximum cycle during a test period of at least 10 cycles if the duct is tested using single-phase ac test current or shall be the peak instantaneous current if tested using a dc source. Preferred ratings are given in Table 11.

Table 9—Isolated-phase bus—rated withstand current

Rated momentary withstand current (kA asymmetrical)	Rated short-time withstand current (kA symmetrical)
As required by connected equipment	As required by connected equipment

5.4.3 Rated short-time withstand current

The rated short-time withstand current of ME bus is the average rms symmetrical current that it can carry for a period of 2 s for segregated- and nonsegregated-phase bus with a rated maximum voltage greater than 0.635 kV ac. The rated short-time withstand current of ME bus is the average rms symmetrical current that it can carry for a period of 1 s for segregated and nonsegregated-phase bus with a rated maximum voltage of 0.635 kV ac, and for all isolated-phase buses. Preferred ratings are given in Table 9, Table 10, and Table 11. The rated short-time withstand current of dc ME bus is the average rms or dc current that it can carry for a period of 250 ms.

6. Tests

6.1 General

This subclause establishes physical and electrical conditions for tests and methods of determining temperature and test values. All apparatus and devices applicable for testing of ME bus shall be mounted in their normal locations during tests.

Tests are classified as design tests, production tests, and field tests. (Refer to Clause 2.)

NOTE—Except for switches and disconnecting links (when supplied), other devices, such as instrument transformers, which are mounted in the bus assemblies, should be disconnected during dielectric tests. Such devices are individually tested in accordance with standards applying to them.

**Table 10—Segregated and nonsegregated-phase bus—
preferred rated withstand current**

Rated maximum voltage (kV ac)	Rated short-time withstand current (kA rms symmetrical)	Rated momentary withstand current ^a	
		(kA rms asymmetrical)	(kA peak)
0.635	22.0	29	51
	42.0	56	97
	65.0	86	150
	85.0	113	196
4.760	31.5	49	82
	40.0	62	104
	50.0	78	130
	63.0	98	164
8.250	40.0	62	104
15.000	20.0	31	52
	25.0	39	65
	31.5	49	82
	40.0	62	104
	50.0	78	130
	63.0	98	164
15.500	20.1	31	52
	31.5	49	82
	40.0	62	104
27.000	16.0	25	42
	25.0	39	65
38.000	16.0	25	42
	25.0	39	65
	31.5	49	82
	40.0	62	104

^aTo obtain the momentary withstand current value in rms asymmetrical amperes, multiply the short-time withstand current rating by 1.33 for bus rated up to 0.635 kV ac and by 1.55 for bus rated above 0.635 kV ac. To obtain the peak momentary withstand current value, multiply the short-time withstand current rating by 2.3 for bus rated up to 0.635 kV ac and by 2.6 for bus rated higher than 0.635 kV ac. To obtain the peak momentary withstand current value for dc bus, multiply the short-time withstand current by 1.65. The multiplying factors (2.6 and 1.55) for bus duct rated higher than 0.635 kV ac are in accordance with the introduction of ANSI C37.06-2000 [B3].⁹ The multiplying factors (2.3 and 1.33) for bus rated up to 0.635 kV ac are in accordance with Note 5 of 5.4.4 of IEEE Std C37.20.1-2002 [B14]. The multiplying factor (1.65) for dc bus is in accordance with 5.5 of IEEE Std C37.14 -2002 [B13], and 6.2.4.1.1 of IEEE Std C37.20.1-2002 [B14].

⁹The numbers in brackets correspond to those in the bibliography in Annex B.

Table 11—DC bus duct—preferred rated withstand current

Rated maximum voltage (V)	Rated short-time withstand current (kA rms symmetrical)	Rated momentary withstand current ^a (kA peak)
300 / 325	25.0	41
	42.5	70
	50.0	83
	85.0	140
	100.0	165
800	90.0	149
	120.0	200
1200	60.0	100
	80.0	132
1600	45.0	74
	60.0	100
3200	22.5	37
	30.0	50

^aTo obtain the momentary withstand current value in rms asymmetrical amperes, multiply the short time withstand current rating by 1.33 for bus rated up to 0.635 kV ac and by 1.55 for bus rated above 0.635 kV ac. To obtain the peak momentary withstand current value, multiply the short time withstand current rating by 2.3 for bus rated up to 0.635 kV ac and by 2.6 for bus rated higher than 0.635 kV ac. To obtain the peak momentary withstand current value for dc bus, multiply the short-time withstand current by 1.65. The multiplying factors (2.6 and 1.55) for bus duct rated higher than 0.635 kV ac are in accordance with the introduction of ANSI C37.06-2000 [B3]. The multiplying factors (2.3 and 1.33) for bus rated up to 0.635 kV ac are in accordance with Note 5 of 5.4.4 of IEEE Std C37.20.1-2002 [B14]. The multiplying factor (1.65) for dc bus is in accordance with 5.5 of IEEE Std C37.14-2002 [B13], and 6.2.4.1.1 of IEEE Std C37.20.1-2002 [B14].

6.2 Design tests

Design tests, as applicable, shall be made in accordance with 6.2.1, 6.2.2, 6.2.3, 6.2.4, 6.2.5, 6.2.6, 6.2.7, and 6.2.8. The equipment to be tested shall be in a new and clean condition. The bus conductors may be extended out of the enclosure to permit the attachment of test connections.

6.2.1 Dielectric tests

Power frequency withstand voltage tests (see 6.2.1.1), and lightning impulse withstand voltage tests (see 6.2.1.2) shall be performed on ME bus to demonstrate the ability of the insulation systems to withstand rated voltages in accordance with Table 1, Table 2, Table 3, and Table 4. In addition, dielectric tests shall be made on the bus bar insulation, if supplied, as specified in 6.2.1.3.

Dielectric tests shall be conducted in accordance with IEEE Std 4-1995 and amendment IEEE Std 4a-2001, unless otherwise specified.

The tests on the insulation shall be made under dry conditions at the atmospheric temperature, pressure, and humidity prevailing at the test site. The tests on the insulation system shall be made under the temperature and humidity conditions normally obtained under conditions at the test site with appropriate correction factors for relative air density and humidity applied as outlined in IEEE Std 4-1995. Humidity correction factors shall be based on curves for rod gaps in accordance with 1.3.4 of amendment IEEE Std 4a-2001. The equipment shall be clean and in good condition and contain a minimum of one bus joint per phase.

Test voltages shall be applied between each phase (or pole) individually and ground in the following manner:

- a) For isolated-phase and segregated-phase bus, between each phase and ground, with the other phases and the enclosure grounded.
- b) For dc bus, between each ungrounded conductor and ground, with the other ungrounded conductor (if any) and the enclosure grounded.
- c) For other types of bus, between each phase and ground, with the other phases and the enclosure grounded.
- d) If ME bus includes disconnect switches or disconnect links, the open gap shall be tested with a value of voltage 10% higher than that specified in Table 1, Table 2, Table 3 and Table 4.

NOTE—For the test across the open gap of switches or links at 10% higher voltage, an intermediate point of the voltage source, may, if practicable, be connected to ground and to the frame of the assembly in order that the voltage between any live part and the frame will not exceed that specified in Table 1, Table 2, Table 3, and Table 4. If this is not practicable, the frame may be insulated from ground.

6.2.1.1 Power frequency withstand voltage tests

AC voltage shall have a crest value equal to 1.414 times the rms value specified in Table 1, Table 2, Table 3, and Table 4. The wave shape shall be essentially sinusoidal. The frequency shall be within $\pm 20\%$ of the rated power frequency. For dc bus assemblies, either the power frequency withstand voltage or the dc withstand voltage listed in Table 4 may be used. The test voltage is to be increased gradually from zero to reach the required test value within 60 s and shall be held at that value for 1 min.

6.2.1.2 Lightning impulse withstand voltage tests

The lightning impulse withstand voltage test shall be conducted in accordance with IEEE Std C37.20.2-1999, 6.2.1.2.

6.2.1.3 Test for bus bar insulation

Insulation applied to bus bar shall be tested in accordance with IEEE Std C37.20.2-1999, 6.2.1.3.

6.2.2 Continuous-current tests

Tests shall be conducted to demonstrate the ability of the bus assemblies to meet the temperature rise limitations specified in Table 5 while carrying rated continuous current. Temperature measurements shall be made in accordance with 6.2.2.3 and 6.2.2.4.

The bus assembly shall have a minimum enclosure length of 6 m. It shall have at least one joint (conductor and enclosure) per phase (bolted, clamped, or welded). Ends of the bus shall be sealed. The number of phases tested should be consistent with the number of phases of the application.

NOTE—In the following subclauses, the word bus is used to denote bus assembly.

6.2.2.1 Test area conditions

Temperature tests shall be conducted in a test area that is reasonably free from drafts.

6.2.2.2 Ambient air temperature limits

Tests may be made at any ambient air temperature between 10 °C and 40 °C.

6.2.2.3 Measurement of ambient air temperature

Ambient air temperatures shall be determined by taking the average of the readings of at least three temperature-measuring devices, such as thermometers or thermocouples placed on the side of the bus on the centerline at least 300 mm from the bus enclosure. One of the devices shall be placed at the center of the bus with the others placed 600 mm inward from the ends of the bus enclosure.

The temperature-measuring devices should be immersed in a suitable liquid, such as oil, in a suitable container or reliably attached to a suitable mass of metal.

NOTE—A convenient form for such a container consists of a metal cylinder with a hole drilled partly through it. This is filled with liquid and the temperature-measuring device is placed therein. The size of the container shall be at least 25 mm in diameter and 50 mm high.

6.2.2.4 Method of measuring temperature

Thermocouples shall be used to measure the temperature on the bus assembly and shall be located on the current-carrying member or other metal part. Measurements shall be made at the junction points of insulation and conducting parts to ensure against exceeding the temperature limits of the insulation.

Thermocouples shall be held in intimate contact with the surface being measured by such methods as welding, drilling and peening, or cementing.

The thermocouple on a design test shall be located in a manner so as to measure the hottest spot even though it may involve drilling holes that destroy some parts. It is recognized that thermocouples cannot be located in the actual contact point of line or point contacts without destroying the effectiveness of such line or point contacts. Thermocouples shall be placed as close to bus connections, contacts, bus supports (insulators), and other similar locations as possible without damaging or impeding the contact.

6.2.2.5 Duration of tests

The continuous-current test shall be made for such a period of time that the temperature rise of any monitored point in the assembly has not changed by more than 1.0 °C over a 1 h period, with readings being taken at not greater than 30 min intervals. The equipment is considered to have passed the test if the temperature limits in Table 5 have not been exceeded in any of the three readings.

6.2.2.6 Frequency of test current

The frequency of the test current shall not be less than the rated power frequency of the assembly tested. A sine-wave shape is recommended. The test shall be made with alternating current having a crest value equal to 1.414 times the rms test current. Direct current assemblies may be tested using an ac or dc power supply with an rms ampere output equal to the continuous-current rating.

6.2.2.7 Test connection conductors for use in continuous-current tests

Bus bars utilized for connection of the test sample to the test power source shall be of the same cross sectional area and material as the conductors in the test arrangement. When cables are utilized for connection to the test power source, the cross sectional area of the cables shall be no larger than the conductors of the bus assemblies. Connections between the power source and the test bus assembly shall be made beyond the ends of the test bus enclosure.

6.2.2.8 Continuous-current test power supply

The alternating current bus assembly may be tested at any convenient voltage using a three-phase source of power. Each individual phase current is to be maintained at no less than the rated continuous current. A single-phase source of power may be used provided all poles are connected in series and the current flow in adjacent poles is in opposite directions.

6.2.3 Momentary withstand current test

Momentary withstand current tests shall be made to demonstrate the mechanical ability of the structure, phase buses, ground bus, and connections in ME bus assemblies to withstand the forces produced by the momentary withstand current.

For dc bus, the force due to the momentary withstand current will depend on the physical location of the return path of the current, which is likely to vary in each application. Also, the force will be equal (and opposite) in the positive bus and the negative bus (return path). Accordingly, the supports that secure the bus enclosure against the short-circuit force must possess equal strength to the bus supports used inside the bus enclosure. Since the installation factors are beyond the control of the manufacturer, a dc momentary withstand current test is not normally performed. Instead, the momentary withstand current capability of dc bus is normally demonstrated by means of calculations. If a momentary withstand current test is conducted for dc bus, the test shall be conducted in accordance with 6.2.3.1, with the minimum distance between the dc bus and the return path recommended by the manufacturer, and the test report shall state this distance.

6.2.3.1 Phase buses and connections

Adequacy is demonstrated as follows:

- a) The assembly shall have no breakage of insulation.
- b) If any deformation of the bus bar(s) has occurred, it should not prevent the dielectric test requirements from being met.

The current shall be the rms value, including the dc component, during the maximum cycle as determined from the envelope of the current wave in the maximum offset phase during a test period of at least 10 cycles. The maximum offset shall occur in an outside phase. This test may be made at any convenient voltage.

For dc bus duct, the current shall be the peak instantaneous value at the maximum cycle with a test period of at least 10 cycles if the duct is tested using single-phase ac test current. If a dc test source is used, the test circuit shall produce a current peak of no less than the momentary withstand current rating of the bus duct in approximately 8 ms, with a current duration of at least 167 ms.

The test shall be made on a section of bus having a minimum length of 6 m and shall contain at least one typical joint. Test samples should have the same number of phases as the design application. Tests performed on a three-phase test sample may be applied to designs of less phases providing the design phase spacing is the same or greater than the test phase spacing.

6.2.3.2 Ground bus (if applicable)

A single-phase momentary withstand current test shall be made on the ground bus. The test parameters shall be as described in 6.2.3.1. The circuit resistance shall be measured with a dc current of at least 100 amperes prior to the test as a baseline for performance evaluation. The dc resistance of the circuit after the withstand test shall not exceed 200% of the circuit resistance prior to the withstand test.

The short circuit shall be made between the ends of the ground bus and the nearest phase of the main bus opposite the incoming terminals. Refer to 6.2.3.1 for main bus to power source connections. If the bus duct

enclosure is used as the ground bus, the same tests will be performed with the enclosure in place of the ground bus.

6.2.4 Short-time withstand current tests

Short-time withstand current tests shall be made to demonstrate the electrical adequacy of phase buses, ground bus, and connections in ME bus assemblies to withstand the rated short-time current for a specified time period.

Adequacy is demonstrated as follows:

- a) The assembly shall have no breakage of insulation.
- b) If any deformation of the bus bar(s) has occurred, it should not prevent the dielectric test requirements from being met.

6.2.4.1 Phase bus and connections

This test may be either a three-phase or a single-phase test at any convenient voltage. The duration of the short-time test current shall be as in 5.4.3. If the test current also meets the requirements of 6.2.3, this test may be combined with the momentary withstand current test. For dc bus duct, in order to meet both 6.2.3 and the short-time withstand current test requirements, the initial peak current applied shall be 1.65 times the average rms or dc sustained current value, with a test current duration of at least 250 ms.

The test shall be made on a section of bus having a minimum length of 6 m and shall contain at least one typical joint.

Short-time withstand current tests shall be made for isolated-phase bus to determine that the buses and connection can carry the test current without exceeding a total temperature of 300 °C for copper and 260 °C for aluminum. Requirements and conditions are the same as for momentary withstand current tests (see 6.2.3) except the minimum duration of the test is 1 s.

6.2.4.2 Ground bus (if applicable)

The ground bus shall be capable of carrying the rated short-time withstand current for ME bus assembly and shall be tested single phase. The test duration shall be 2 s for bus rated above 0.635 kV ac, 1 s for bus rated up to 0.635 kV ac, 1 s for isolated-phase bus, and 250 ms for dc bus (if applicable). The test parameters shall be as described in 6.2.4.1. The short circuit shall be made between the ends of the ground bus and the nearest point on the phase bus opposite the incoming terminals. Refer to 6.2.4.1 for bus to power source connections. The circuit resistance shall be measured with a dc current of at least 100 amperes prior to the test as a baseline for performance evaluation. If the bus duct enclosure is used as the ground bus, the same tests will be performed with the enclosure in place of the ground bus.

The dc resistance of the circuit after the withstand test shall not exceed 200% of the circuit resistance prior to the withstand test.

6.2.5 Weather-resistance tests

The enclosure of a weather-resistant bus assembly shall be tested in accordance with the rain test as described in IEEE Std C37.20.2-1999. The test shall be made on a section of bus and shall contain at least one typical joint.

6.2.6 Flame-resistance tests for applied insulation

The flame resistance test for applied insulation shall be conducted as described in IEEE Std C37.20.2-1999, 6.2.8.

6.2.7 Flame-resistance tests

Sheet, molded, or cast primary insulating materials used in ME bus assemblies shall have a minimum average ignition time of 60 s and a maximum average burning time of 500 s when tested in accordance with ASTM D229-1996, Method II.

Tests on sheet, molded, or cast insulating material for support of primary buses and connections shall be performed as described in IEEE Std C37.20.2-1999, 6.2.7.

6.2.8 Paint qualification test

The paint qualification test shall be performed as described in IEEE Std C37.20.2-1999, 6.2.9.

6.3 Production tests

Production tests for ME bus shall be power frequency withstand voltage tests, mechanical operation tests, grounding of instrument transformer case tests, electrical operation checks, and control wiring checks.

6.3.1 Power frequency withstand voltage tests

Power frequency withstand voltage tests shall be made on ME bus in accordance with the general requirements of 6.2.1. Tests shall be made between each phase and ground. For nonsegregated bus, the tests shall be made between each phase and ground with the other phases grounded.

6.3.2 Mechanical operation tests

Mechanical tests, where applicable, shall be performed to ensure the proper functioning of mechanical interlocks, etc.

6.3.3 Grounding of instrument transformer case tests

The effectiveness of instrument transformer case or frame grounding shall be checked by a low potential source, such as 10 V or less, using bells, buzzers, or lights. This test is required only when instrument transformers are of metal case design.

6.3.4 Electrical operation and control wiring tests

6.3.4.1 Control wiring continuity

The correctness of the control wiring of a bus assembly shall be verified by either or both of the following:

- a) Actual electrical operations of the component control devices
- b) Individual circuit continuity checks by electrical circuit testers

6.3.4.2 Control wiring insulation test

A 60 Hz test voltage shall be applied after all circuit grounds have been disconnected. Either 1500 V for 1 min or 1800 V for 1 s may be utilized. All wires shall be tested either individually or in groups. At the option of the manufacturer, bus mounted devices that have been individually tested may be disconnected during the test.

6.4 Field tests

In addition to the following, manufacturer's recommendations should be considered.

6.4.1 Weather-resistance

A weather-resistant bus installation may be tested in the field to determine the adequacy of field welds, assembly of bus sections, covers, gaskets, etc. The adequacy of these functions can be assessed using the weather-resistant design test method as described in 6.2.5, or for isolated-phase bus, by the following air tightness method:

- a) Fill the bus (or section) to be tested with air to a pressure of 1500 Pa.
- b) Cover the field (and factory) welds and joints with soap bubbles to detect escaping air. If air leakage occurs, consult the manufacturer.

6.4.2 Dielectric tests

When power frequency withstand voltage tests are made on ME bus after installation in the field, the test voltage shall not be greater than 75% of the test values given in Table 1, Table 2, Table 3, and Table 4.

NOTE—Field tests are recommended when new sections are added to an existing installation or after major field modifications. The bus should be put in good condition prior to the field test. It is not expected that the bus shall be subjected to these tests after it has been stored for long periods of time or has accumulated a large amount of dirt, moisture, or other contaminants without first being restored to good condition.

6.4.3 Forced-air cooled bus

Inspection of and measurements on a forced-air cooled bus should be made and the parameters checked against the manufacturer's specifications. These should include the following:

- a) Fan rotation and speed
- b) Fan and motor vibration
- c) Motor operating voltage and load current (as a check against brake horsepower)
- d) Heat exchange coolant flow rate and temperature
- e) Air balance within the bus system
- f) Alarm and indicating device settings and/or calibration (thermostats, thermometers, pressure switches, etc.)

NOTE—Most systems utilize turbulent air flow, which makes air measurements difficult. Generally air balance is checked by measuring the temperature rise of the bus under load conditions. However, the manufacturer's recommendations for the specific installation should be followed.

7. Construction

7.1 Materials and finish

7.1.1 Materials

The materials for the ME bus enclosure shall be sheet metal suitably supported. All covers, barriers, and panels shall not be less than MSG No. 14 [nominal thickness of 0.0747 in (1.9 mm)]. Panels or covers used to support devices shall be increased in thickness or otherwise strengthened, as necessary to support the devices. Barriers between phases of segregated-phase bus shall not be less than MSG No. 11 [nominal thickness of 0.1196 in (3 mm)].

7.1.2 Finishes and color

All steel surfaces to be painted shall receive a phosphatizing treatment or equivalent prior to application of paint. Painted external and steel internal surfaces shall be coated with at least one coat of corrosion-resisting paint. The finish paint system shall comply with the requirements of 6.2.8. The interior of aluminum enclosures and interior aluminum detail parts do not require painting.

The preferred color for finish on ME bus shall be light gray No. 61 per ASTM D1535-2001 (Munsell Notation 8.3 G6. 0.54).

NOTE—Internal detail parts may have metallic plating or equivalent in lieu of paint finish.

7.2 Grounding

A continuous ground conductor shall be provided in parallel with the bus to ensure that all enclosures are grounded. The ground bus may take the form of a separate bar (copper or aluminum), or it may be the enclosure itself, if a continuous electrical path can be provided of the same momentary withstand current rating as the main bus conductors. The ground bus shall be capable of carrying the rated short-time withstand and momentary withstand current of the bus.

The ground conductor is preferably connected to the station ground at one point only, although more connection points are satisfactory if induced current loops have been avoided. Induced voltages across insulated joints in the housing should be kept as low as possible and preferably below 2 V during rated current operation.

7.3 Adjacent and supporting structure

For high-current installations, consideration should be given to the problem of induced circulating current in nearby metallic members, such as support beams, reinforcing rods, etc. Suitable insulated gaps in the steel members will aid in solving the problem.

It is recommended that the ground currents in any adjacent metallic material be kept to a minimum so temperature rise is within the limits shown in Table 5.

7.4 Ventilation

Widely fluctuating ambient air temperatures for one section of bus necessitate consideration of the resulting enclosure air temperature; a form of ventilation with filtered breathers or means for air circulation should be provided. If the insulation system is organic, heaters may be used to control condensation inside the bus enclosure.

7.5 Force-cooled

Auxiliary equipment may be used to force-cool ME bus. Either a gas, a liquid, or combination of these media are satisfactory for force-cooled bus. The system may be of the open or of the recirculatory type. Precautions shall be taken to prevent transmittal of arc products between phases. A force-cooled bus will carry a lower-than-normal current when the cooling medium is not being circulated, and both the force- and self-cooled values of current shall be indicated in the rating.

7.5.1 Forced-air-cooled, isolated-phase bus

Forced-air-cooled, isolated-phase bus generally consists of the components described in 7.5.1.1 through 7.5.1.3.

7.5.1.1 Isolated-phase bus structure with provisions for connection to a cooling unit

Connections between the bus structure and the cooling unit should provide for vibration isolation. Electrical insulation shall be provided at such connections to prevent circulating currents between the two components.

7.5.1.2 Cooling unit with necessary air duct and connections to the bus structure¹⁰

Cooling units may be of the recirculatory type, the non-recirculatory or “once through” type, or of a type convertible from recirculatory to non-recirculatory.

7.5.1.2.1 Recirculatory cooling units

Recirculatory cooling units consist of a motor-driven fan,¹¹ a suitable heat exchanger (generally air-to-water);¹² and provisions to admit air lost by leakage into the system through filtered openings in the air duct.

Cooling air is circulated through the bus assembly by the motor-driven fan. After completing the circulation, the cooling air is returned to the cooling unit through the air duct, is cooled by being passed through the heat exchanger, and returns to the motor-driven fan for recirculation through the bus.

7.5.1.2.2 Non-recirculatory or “once through” cooling units

Non-recirculatory cooling units consist of a motor-driven fan and provisions to admit filtered ambient air into the system. The filtered cooling air is circulated through the bus assembly by the motor-driven fan and, after completing the circulation, is exhausted to the atmosphere.

7.5.1.2.3 Convertible-type cooling units

Convertible cooling units have provisions to convert from a recirculatory cooling system to a non-recirculatory or “once through” system when the heat exchanger is out-of-service.

7.5.1.3 Indicating devices

Suitable devices on the bus system and cooling units shall be provided to perform the following functions:

- a) Indicate the bus conductor temperature at possible hot spots
- b) Indicate, for alarm purposes, bus overtemperature at possible hot spots
- c) Indicate, for alarm purposes, loss of cooling air to the bus system
- d) Indicate, for alarm purposes, insufficient or excessive coolant flow to the heat exchanger
- e) Indicate, for alarm purposes, accumulation of water in the heat exchanger drain pan

7.5.1.4 Means to transfer cooling air between phases

When cooling air is transferred between phases, means shall be provided to reduce the possibility of the transfer of ionized air between phases due to a phase-to-ground fault in the bus. Grounded deionizing baffles, grids, or similar means shall be provided for this purpose. If necessary for air balancing, adjustable dampers shall be provided. Such dampers shall have provisions for locking in any position, and their open and closed positions shall be indicated.

¹⁰ Additional indicating devices, fans, motors, and heat exchangers may be added to the basic equipment outlined to provide redundancy.

¹¹ Special consideration shall be given to the drive motor, such that under any operating conditions it will not exceed its horsepower rating.

¹² The heat exchanger construction shall be such that possible condensation will not be carried into the fan.

7.6 Vapor barriers

Self-cooled ME bus having sections located inside and outside a building, so that ambient temperature may be appreciably different at the same moment, shall include sealing means or baffles to prevent an interchange of air between the sections.

7.7 Fire barriers

Self-cooled buses may propagate smoke and fire from one part of the building to another unless barriers are installed at strategic locations. Fire barriers to prevent passage of fire and smoke may be required at all floor-lines of vertical buses and in horizontal runs of buses whenever the buses pass through walls designated as “fire walls.”

7.8 Insulating materials for covering buses and connections

If insulation is provided on the bus conductors, it shall have been design tested for dielectric strength and flame resistance as outlined in 6.2.1.3 and 6.2.6. Where joints are required to be made up on the jobsite, insulating materials shall be supplied for application in accordance with the manufacturer’s instructions.

7.9 Terminations and flexible connections

The bus is electrically attached to the studs of generator or transformer bushings or switch terminal pads, usually with flexible braid or multiple laminations depending on the degree of flexibility required.

Similar flexible connections may be required in long, straight runs of bus to provide for temperature expansion or contraction, or where the bus crosses building vibration isolation joints.

The terminating equipment at the generator may require seal-off bushings or baffles with provision for escape of hydrogen to the atmosphere from leaks in or around the generator bushings.

7.10 Switches or links for station-service transformers

Generator bus frequently has tap connections to station-service transformers through group-operated switches or disconnecting links. Switches shall be designed to interrupt only the magnetizing current of the transformer and should not be operated to close onto an energized bus unless designed for closing duty. Links should be easily removable, but should only be removed when the bus is de-energized. The switches and links shall be capable of carrying the rated short-circuit current in that section of bus.

7.11 Secondary wiring

7.11.1 Control and secondary wiring

Flame-resistant, 600 V insulated copper wire, with a cross-sectional area not less than AWG No. 14 stranded (2.5 mm²) shall be used on small wiring between component devices or parts of bus assemblies. Where wire is connected across a hinge, flexible (37 or more strands) wire shall be used.

Bushings, grommets, or other mechanical protection shall be provided for the wiring where control or secondary wiring is run through a metal sheet, barrier, or raceway.

The internal wiring of component devices or parts shall be in accordance with the applicable industry standards.

The insulated wire shall be Type SIS as listed in NFPA 70-2002 or an equivalent and shall meet the requirements of NEMA WC70-1999/ICEA S-95-658-1999 as applicable.

7.11.2 Secondary-wiring terminals

Stranded control wire shall have solderless terminals of the type wherein the body of the terminal is crimped or indented onto the conductor. Solderless terminals are not required for connection to devices that have integral pressure terminal connections.¹³

7.11.3 Terminal blocks

Terminal blocks incorporating screw or stud-and-nut-type terminals shall accommodate wire lugs or similar devices affixed to stranded wire. Screw or stud-and-nut-type terminals intended for use with stranded wire shall be such that all strands of the conductor are confined. Terminal blocks incorporating pressure connectors shall not damage the wire, and when terminating stranded conductors, all strands shall be clamped within the connector.

Terminal blocks for external connections shall be suitable to accept AWG No. 10 (5.26 mm²) stranded wire. The use of solid wire is not recommended.

7.11.4 Nameplate marking

The following minimum information (as applicable) shall be given on ME bus assemblies nameplates:

- a) Manufacturer's name and address
- b) Manufacturer's type designation (optional)
- c) Manufacturer's identification reference
- d) Rated maximum voltage
- e) Rated power frequency
- f) Rated continuous current
- g) Rated insulation levels
 - 1) Power frequency withstand voltage
 - 2) Lightning impulse withstand voltage
- h) Rated short time withstand current
- i) Rated momentary withstand current (kA rms asym.)
- j) Rated momentary withstand current (kA peak)

8. Miscellaneous accessories

ME bus equipment installations may include such accessories or auxiliaries as potential transformers and/or surge protection equipment cubicles, generator neutral connections, and disconnect switches. Current transformers may also be mounted in the bus. High-current rated bus may include bushings having provision for mounting a current transformer. Location of current transformers shall be coordinated with joints in the bus so that current transformers are accessible.

All such accessories shall conform to the voltage and insulation levels of this standard. Devices such as instrument transformers, however, may not withstand the dielectric tests of the equipment and should be disconnected when such tests are made.

¹³ In the absence, within this standard, of definitive performance requirements, compliance with this subclause can be assessed by referencing UL 486A-1997 [B23].

The connection between the cubicles and ME bus may be arranged with seals or baffles to prevent faults in the cubicles from reaching the main conductors of ME bus. The potential transformers and/or surge protection equipment cubicles supplied with isolated-phase bus may continue the isolated-phase concepts (i.e., single-phase cubicles with insulation air space between phases); with this construction, the primary bus conductors and connections in the cubicles are bare. Otherwise, cubicles are constructed in accordance with the requirements for equipment in IEEE Std C37.20.2-1999.

9. Application guide for ME bus in unusual service conditions

It is strongly recommended that the usual service conditions, as described in Clause 4, be provided for ME bus applications, if practical (artificially, if necessary). However, if unusual conditions exist and cannot be eliminated, the considerations given in the subclauses of Clause 9 apply.

NOTE—Any unusual service condition should be specified by the user.

9.1 Ambient air temperature above 40 °C

When ME bus is applied where the ambient air temperature is higher than 40 °C, its performance may be affected and special consideration should be given to these applications. The total temperature limits for parts and materials as listed in Table 5 and Table 6 should not be exceeded. Therefore, for the higher ambients, the equipment should be derated in accordance with IEEE Std C37.20.2-1999 (except the exponential power shall be 1/1.7) to a continuous current value that maintains the total temperature limits (in accordance with Table 5 and Table 6).

9.2 Ambient air temperature below –30 °C

Special consideration is also required when ME bus is applied where the ambient air temperature is less than –30 °C for significant periods of time. Space heating and thermal insulation to minimize the effects of exposure should be considered. If this is not possible, the effect of low temperatures on the functional performance of such materials as plastic insulation on primary and secondary circuits, control wire insulation, and lubricants should be considered.

9.3 Application at unusual altitudes

ME bus assemblies will have a higher temperature rise and a lower dielectric withstand capability when operated at altitudes above values specified in item b) of Clause 4. For applications at higher altitudes, the rated maximum voltage, the rated power frequency withstand voltage, the lightning impulse withstand voltage, and continuous current rating of the assemblies should be multiplied by the correction factors in Table 12 to obtain the modified ratings.

9.4 Other conditions that may affect design and application

Where other conditions exist, they should be brought to the attention of those responsible for the design and application of ME bus. Among such conditions are the following:

- a) Unusual installation requirements, space or ventilation limitations, special duty, frequency or other operating requirements, difficulty of maintenance, or building construction
- b) High wind, ice loads, and snow loads
- c) Installations accessible to the general public
- d) Temperature limits of connected equipment (see Table 5)

- e) Installations where the rated momentary withstand current or rated short-time withstand current ratings or both, specified in Table 10 and Table 11, may be exceeded
- f) Exposure to significant solar radiation (the principles stated in IEEE Std C37.24-1986 may be used for guidance)

NOTE—There is disagreement in the industry regarding the effect of solar radiation on ME bus. There has been little systematic study of the effect of solar radiation on ME bus that is comparable to the studies on ME switchgear. However, it is reasonable to expect that significant solar radiation will reduce the continuous current carrying capability of ME bus to some degree. Therefore, in the absence of definitive studies of the effect, use of the information in IEEE Std C37.24-1986 to guide the application of ME bus in the presence of significant solar radiation will result in a conservative application. For more specific application guidance, consult the manufacturer.

Table 12—Altitude correction factors (ACF)

Altitude (m)	ACF for withstand voltages	ACF for continuous current
1000	1.00	1.000
1200	0.98	0.995
1500	0.95	0.991
1800	0.92	0.987
2000	0.91	0.985
2100	0.89	0.980
2400	0.86	0.970
2700	0.83	0.965
3000	0.80	0.960
3600	0.75	0.950
4000	0.72	0.940
4300	0.70	0.935
4900	0.65	0.925
5500	0.61	0.910
6100	0.56	0.900

NOTES

1—All values are under review by an IEEE Switchgear Committee working group and are provided here for reference until revised values are available.

2—Intermediate values may be obtained by interpolation.

3—For devices used in switchgear assemblies, standards covering the specific devices should be used to determine the specific ACFs.

9.5 Modification of equipment for unusual environment

Successful performance of standard ME bus may be extended to unusual environments by special considerations when developing equipment specifications. Several construction modifications that will mitigate the effects of these environments may be made in accordance with 9.5.1, 9.5.2, 9.5.3, 9.5.4, 9.5.5, and 9.5.6, but

the emphasis should be on eliminating such conditions, if at all possible. However, if these undesirable conditions cannot be eliminated, more frequent maintenance may be required.

9.5.1 Exposure to damaging fumes, vapors, steam, salt air, and oil vapors

Indoor and outdoor bus assemblies should be provided with the following modifications:

- a) Minimum of two coats of paint, one of which should be a corrosion- or rust-resisting primer, on all structural parts.
- b) All steel parts that are not painted or plated should be covered with protective grease.
- c) All current-carrying joints should be covered with a coating of nonoxidizing grease.
- d) Heaters, in quantity and rating sufficient to minimize condensation should be furnished.

9.5.2 Exposure to excessive dust, abrasive dust, magnetic or metallic dust

Totally enclosed, nonventilated bus assemblies should be supplied for both indoor and outdoor locations. Internal condensation could be a factor and anti-condensation measures should be evaluated.

Should a ventilated bus duct assembly be supplied, ventilation filters should be furnished to filter the dust from the air and deter internal contamination. Filter manufacturers should be consulted to verify the appropriateness of the filter to the application. Periodic cleaning and/or changing of the filters should be in accordance with the filter manufacturer's recommendations. Where very fine dust particles are to be excluded, disposable filters soaked in oil should be used and changed at frequent intervals.

Forced ventilation may be required depending upon the volume of air required for ventilation and the severity of the environment. When furnished due to environment, the blower and filter should be installed on the intake to minimize the possibility of drawing dust or other foreign matter into and throughout the bus assembly.

9.5.3 Exposure to hot and humid climates

Indoor and outdoor bus assemblies for exposure to hot and humid climates should be made fungus-resistant by the following modifications:

- a) Heaters in quantity and rating sufficient to minimize condensation should be furnished.
- b) Secondary wiring that is not inherently fungus-resistant should have fungus-resistant coating applied. Secondary wiring that has fungus-resistant insulation should not require further treatment.
- c) Paints such as alkyd enamels having a fungus- and rust-resistant property should be used.

Insulation that is not inherently fungus-resistant should have fungus-resistant coating applied. Insulation in bus assemblies that is inherently fungus-resistant should not require further treatment. Fungus-resistant coatings should not be applied where they will interfere with proper operation of apparatus. In such cases, the part should be inherently fungus-resistant. These coatings should not reduce the flame-resistant properties.

The fungus resistance of materials should be determined in accordance with ASTM G21-1996. Materials to be classified as fungus-resistant should have a rating not greater than 1.

Materials that are made fungus-resistant by means of a coating should have the coating reapplied at periodic intervals.

9.5.4 Exposure to explosive mixtures of dust or gases

Application of ME bus in hazardous (classified) locations requires special consideration in construction and installation practices. Consult the NEC for special requirements relating to the use of electrical equipment in hazardous (classified) locations.

9.5.5 Exposure to abnormal vibration, shocks, or tilting

Indoor and outdoor bus assemblies are designed for mounting on level structures free from vibration, shocks, or tilting.

Since these conditions vary so widely, it is recommended that the manufacturer be consulted for each specific application where vibration, shocks, or tilting are to be encountered.

It is important that the full nature of the abnormal motion be specified. The magnitude and frequency range of the dynamic motion is required so that resonances may be investigated.

In the case of tilting, it is also important that the maximum angles of tilt, both transverse and longitudinal, be specified. The exact performance requirements should also be defined. It should be recognized that equipment that is specifically designed for a usual installation on a substantially level surface free from excessive vibration, shock, or tilting may be damaged and may not be able to function properly when subjected to excessive motion and displacement. Hence, the application should be carefully analyzed and the essential performance requirements should be precisely defined.

9.5.6 Exposure to seismic shock

Because of the importance of adequate performance of equipment when applied as Class 1E equipment in a nuclear power generating station, IEEE Std 344-1987 was developed for this application. Consideration should be given to special requirements that may be necessary to meet requirements of the site seismic zone. See also IEEE Std C37.81-1989.

Annex A

(informative)

Guide for calculating losses in isolated-phase bus

A.1 General

The information in this annex is applicable to all forms of isolated-phase buses operating in ac power systems. It does not apply to nonsegregated- or segregated-phase ME bus.

All conductors carrying electric current will produce power losses. This guide covers methods for calculating conductor and enclosure losses at bus operating temperatures, including skin effect. In making power loss calculations, the I^2R losses in the enclosure are considered. Means for determining such losses for various bus configurations are included. If the bus is force-cooled, the power requirements of the cooling equipment will be included in the total power loss.

For high-current installations, consideration should be given to the problem of induced magnetic heating and induced circulating current in nearby metallic members, such as support beams and reinforcing rods. The guide also contains references to assist in the estimation of heating effects of adjacent structural members. Such induced currents should be minimized to reduce extraneous losses. Methods of reducing eddy current and hysteresis losses and eliminating losses due to circulating currents are indicated.

A.2 Conductor losses

A.2.1 General

The loss in each conductor is shown in Equation (A.1):

$$P_c = I^2 R_c \quad (\text{A.1})$$

where

- R_c = conductor resistance at the appropriate temperature with skin effect corrections for the applicable frequency,
- I = conductor current.

It is convenient for the purpose of this guide to determine the losses per unit length of conductor. Thus, if R_c is expressed in microhms per foot ($\mu\Omega$ /ft) and I in kiloamperes rms (kA rms), P_c will be expressed in watts per foot (W/ft). Alternatively, if R_c is expressed in microhms per meter ($\mu\Omega$ /m) and I in kiloamperes rms (kA rms), P_c will be expressed in watts per meter (W/m).

The conductor resistance may be obtained from tables or calculated from its dimensions and resistivity. Equation (A.11a) or Equation (A.11b) may be used to calculate the resistance of round hollow conductors.

The current for which the loss is calculated shall be the rated continuous current.

A.2.2 Temperature effects

A.2.2.1 Conductor operating temperature

The losses should be calculated for the operating temperature of the conductor. The maximum operating temperature limit specified in Table 5 of this standard for isolated-phase bus conductors follows in Table A.1:

Table A.1—Temperature limits for isolated-phase bus

Bus conductor	Maximum temperature limit of hottest spot (°C)
Bus conductor with plain (unplated) connection joints	70
Bus conductor with silver, or equivalent contact surfaces	105

The maximum temperature limit is based on 40 °C ambient. The total temperature of the bus conductor at current below full load and at other ambients can be approximated by using Equation (A.2) and Equation (A.3):

For a 105 °C bus:

$$T_{B105} = T_{amb} + \left[\left(\frac{\%load}{100} \right)^n \cdot 65 \right] \quad (A.2)$$

where

- T_{amb} = ambient temperature,
- T_{B105} = bus temperature at % load for a 105 °C bus.

For a 70 °C bus:

$$T_{B70} = T_{amb} + \left[\left(\frac{\%load}{100} \right)^n \cdot 30 \right] \quad (A.3)$$

where

- T_{amb} = ambient temperature,
- T_{B70} = bus temperature at % load for a 70 °C bus.

The suggested value of exponent n is 1.7 for self-cooled buses and 2.0 for force-cooled buses.

A.2.2.2 Change in dc resistance with temperature

Most tables list the dc resistance of conductors at 20 °C. The resistance at other temperatures may be determined from Equation (A.4):

$$R_t = R_{20} [1 + \alpha_{20} (t - t_0)] \quad (A.4)$$

where

- α_{20} = temperature resistance coefficient at 20 °C,
- t_0 = 20 °C,
- R_{20} = dc resistance at 20 °C,
- R_t = dc resistance at temperature t .

The temperature resistance coefficient depends upon the material used for the bus conductor and its conductivity. For 100% conductivity copper, $\infty_{20} = 0.00393$; for 98% conductivity, copper $\infty_{20} = 0.00385$. This may be written as shown in Equation (A.5):

$$R_t = R_{20}[1 + k_3\gamma(t - t_0)] \tag{A.5}$$

where

- γ = conductivity,
- k_3 = constant depending upon material.

For aluminum, and when γ is expressed in percent of the annealed copper standard, $k_3 = 0.000066$.

A.3 Skin effects

In the curves shown in Figure A.1 and Figure A.2 (for round conductors and enclosures) and Figure A.3 (for square conductors), the skin effect factor R_{ac}/R_{dc} is plotted against $\sqrt{(f \cdot 10^3)/R_{dc}}$ for various conductor thickness/diameter ratios where the resistances are in microhms per foot (or $\sqrt{(f \cdot 10^3 \cdot 3.28083)/R_{dc}}$ where the resistances are in microhms per meter). The data in Figure A.1 and Figure A.2 for values of t/d of 0.03 and greater and all data in Figure A.3 are derived from formulas given in Dwight [B25]. In Figure A.1 and Figure A.2, data for values of t/d of 0.025 and less have been calculated to extend the range of $\sqrt{(f \cdot 10^3)/R_{dc}}$ (or $\sqrt{(f \cdot 10^3 \cdot 3.28083)/R_{dc}}$) to cover values for large-diameter enclosures. Figure A.3 can also be used in conjunction with two channels arranged to form a square conductor without introducing appreciable error. These curves apply for both copper and aluminum conductors. The curves can be used for all temperatures within operating ranges.

To calculate heat loss, use Equation (A.1).

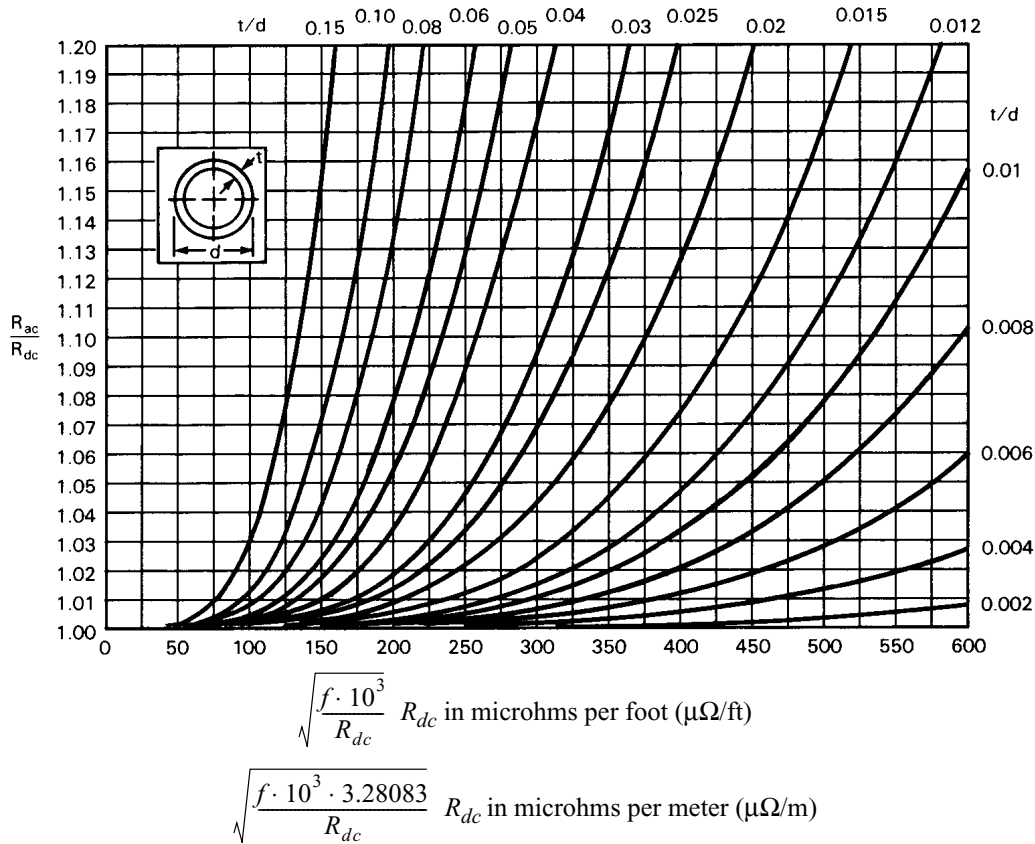
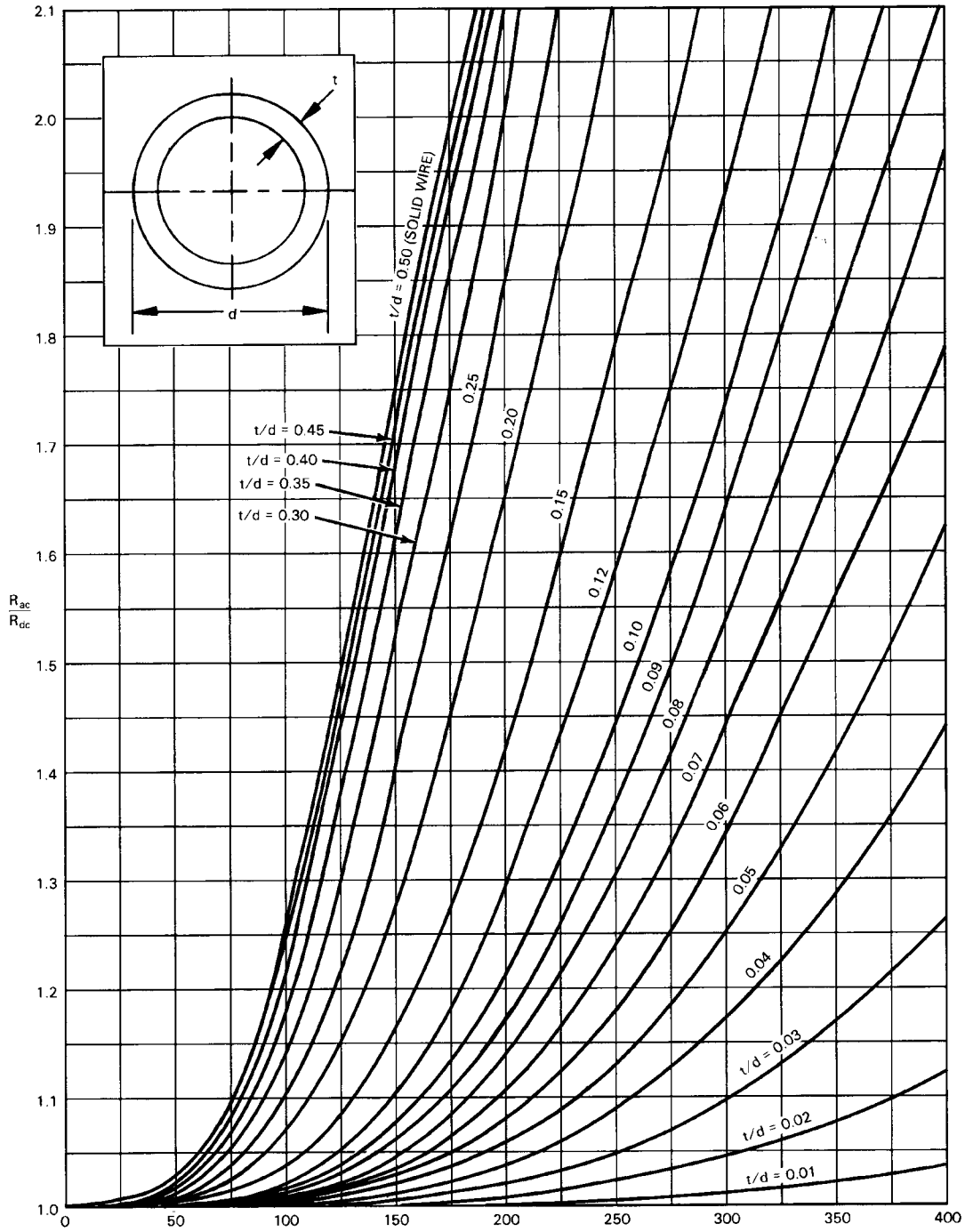

Figure A.1—Curves for skin effect of isolated tubular conductors



$$\sqrt{\frac{f \cdot 10^3}{R_{dc}}} \quad R_{dc} \text{ in microhms per foot } (\mu\Omega/\text{ft})$$

$$\sqrt{\frac{f \cdot 10^3 \cdot 3.28083}{R_{dc}}} \quad R_{dc} \text{ in microhms per meter } (\mu\Omega/\text{m})$$

Figure A.2—Curves for skin effect of isolated round rod and tubular conductors (Dwight [B25])

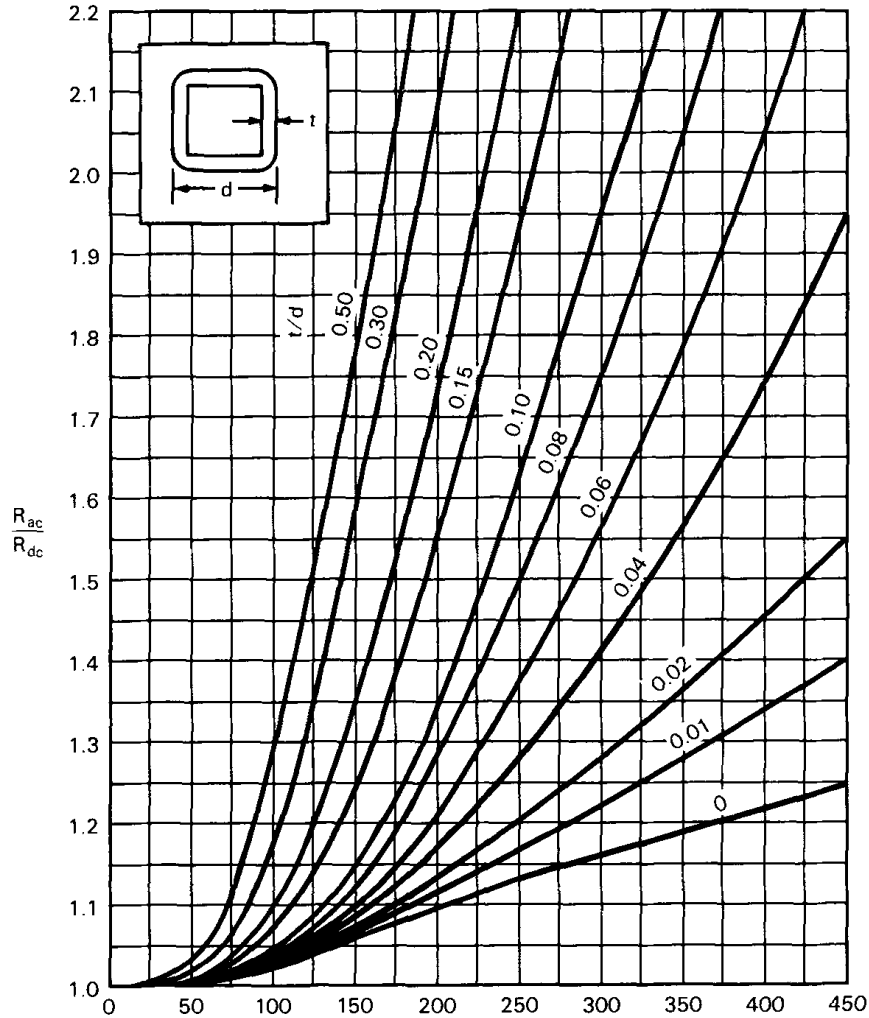

$$\sqrt{\frac{f \cdot 10^3}{R_{dc}}} \quad R_{dc} \text{ in microhms per foot } (\mu\Omega/\text{ft})$$

$$\sqrt{\frac{f \cdot 10^3 \cdot 3.28083}{R_{dc}}} \quad R_{dc} \text{ in microhms per meter } (\mu\Omega/\text{m})$$

Figure A.3—Curves for skin effect of isolated round rod and tubular conductors (Dwight [B25])

A.4 Enclosure losses

A.4.1 Definitions

A continuous isolated-phase bus enclosure (see Figure A.4) is one in which the consecutive sections surrounding the same phase conductor are electrically connected to each other over the length of the installation and cross-connected to the enclosures of the other phases at the extremities of the installation, so as to permit longitudinal current flow in the enclosures. Electric connection-to-ground may be made at any convenient point. (This type of enclosure is referred to as a bonded enclosure.)

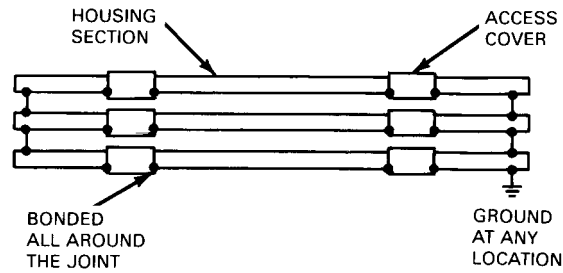

Figure A.4—Continuous isolated-phase bus enclosure

A noncontinuous isolated-phase bus enclosure (see Figure A.5) is one in which the consecutive enclosure sections surrounding the same phase conductor are electrically insulated from each other so as to prevent longitudinal current flow across the enclosure joints. Each enclosure section is connected to a ground bus at one point only (this type of enclosure is referred to as an insulated enclosure).

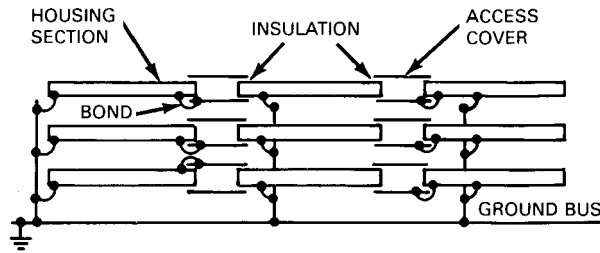

Figure A.5—Noncontinuous isolated-phase bus enclosure

The enclosure factor, ι^2 , is a parameter defined as shown in Equation (A.6):

$$\iota^2 = \frac{\kappa_5 \pi D t \omega}{\rho} \quad (\text{A.6})$$

where

D = enclosure mean diameter = $d/2 + t$,

d = enclosure outside diameter,

t = enclosure wall thickness,

$\omega = 2\pi f$,

f = frequency,

ρ = resistivity of the enclosure material,

κ_5 = constant depending on units used (for units of the SI system, $\kappa_5 = 10^{-7}$).

For practical computation, ι^2 may be expressed as shown in Equation (A.7):

$$\iota^2 = \frac{\kappa_6 f}{R_e} \quad (\text{A.7})$$

where

R_e = resistance of enclosure per unit length,

κ_6 = constant (if R_e is expressed in $\mu\Omega/\text{ft}$ and f in Hz, $\kappa_6 = 0.1915$).

The spacing factor is the ratio D/S , where D is the enclosure mean diameter and S is the spacing of conductor centerlines, with D and S in the same units.

The virtual enclosure loss is a fictitious loss, based upon the assumption that the enclosure current is the same as the conductor current, expressed by $I^2 R_e$, where R_e is the enclosure longitudinal resistance and I is the conductor current. The loss factor κ is a number relating the actual enclosure loss to the virtual loss defined previously. The value of κ depends on the installation parameters, the type of enclosure (continuous or noncontinuous), and the relative magnitudes and phase angles of the conductor currents in each particular arrangement.

A.4.2 Power loss in enclosures

Currents flowing in the main conductors induce voltage in the enclosures. The voltages cause currents that flow in patterns, depending on how the enclosures are interconnected. Current flow in the enclosures produces heat loss, which may be expressed as shown in Equation (A.8):

$$P_e = KI^2 R_{(ac)e} \quad (\text{A.8})$$

where

K = loss factor, for the total loss in all three enclosures of a three-phase run or both enclosures of a single-phase tap for the particular enclosure and arrangement. (A single-phase tap refers to the connections to one transformer of a three-phase bank as shown in Figure A.6.),

$R_{(ac)e}$ = ac resistance of the particular enclosure corrected to the operating temperature of the enclosure,

I = line current in the main conductors of the bus run. (Even when the losses in single-phase taps are unbalanced, three-phase balanced runs are considered.)

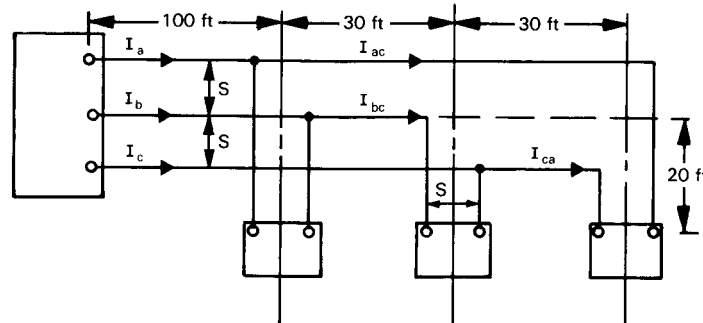

Figure A.6—Layout of isolated-phase bus installation

A.4.3 Temperature effects

A.4.3.1 Enclosure operating temperatures

The loss should be calculated at the assumed operating temperature of the enclosure, or at the maximum temperature specified in Table 5 of this standard, as is appropriate for the installation. The maximum limit of total temperature specified in Table 5 of this standard for the bus enclosure is

- a) Accessible parts: 80 °C
- b) Nonaccessible parts: 110 °C

The interpretation given here is that those portions of the enclosure in which currents are induced will be accessible. The effects of local hot spots due to current crowding and deviations due to normal ventilation and external heat sources and heat sinks may be ignored in loss calculations.

A.4.3.2 Continuous enclosures

The temperature rise of each of the continuous enclosures in a three-phase installation and for force-cooled buses will be relatively uniform. The total temperature at conductor currents below full load and at ambients other than 40 °C can be approximated as shown in Equation (A.9):

Enclosure temperature (°C at % load)

$$T_{enc} = T_{amb} = \left[\left(\frac{\%load}{100} \right)^n \cdot 40 \right] \quad (A.9)$$

where

T_{enc} = enclosure temperature (°C at % load),

T_{amb} = ambient temperature.

The suggested value of n is 1.7 for self-cooled buses and 2.0 for force-cooled buses.

A.4.3.3 Noncontinuous enclosures

In the case of noncontinuous construction, the temperature rise of one of the enclosures will exceed that of the other two. Therefore, the average temperature of the three enclosures at full load will be less than the limit set by this standard. For loss calculations, the operating temperature of noncontinuous enclosures at conductor currents below full load and at ambients other than 40 °C may be approximated by the use of Equation (A.3) if the average temperature rise of the enclosure at full load is assumed to be 30 °C.

A.4.3.4 Enclosure resistance

The resistance of a large-diameter enclosure with a thin-wall section may be closely approximated by the expression shown in Equation (A.10):

$$R_{e(20)} = \rho \frac{L}{\pi D t} \quad (A.10)$$

where

ρ = resistivity of the enclosure material at 20 °C,

L = length of bus enclosure,

D = enclosure mean diameter,

t = enclosure wall thickness.

Enclosures are generally made of aluminum of specified conductivity. Since losses are usually determined per unit length, it is convenient to determine $R_{e(20)}$ for unit length in the units used. For a length of one meter (or one foot), with D and t in millimeters (or inches), and conductivity expressed in percent, Equation (A.10) becomes Equation (A.11a) for feet and Equation (A.11b) for meters:

$$R_{e(20)} = \frac{259}{Dt\gamma} \quad (\mu\Omega/\text{ft}) \quad (\text{A.11a})$$

$$R_{e(20)} = \frac{548215}{Dt\gamma} \quad (\mu\Omega/\text{m}) \quad (\text{A.11b})$$

where

γ = conductivity

Since the temperature at which the losses are desired is generally different from 20 °C, R_e as determined by Equation (A.10), Equation (A.11a), or Equation (A.11b) must be adjusted to the appropriate temperature. Equations for temperature corrections are given in A.2.2.2.

A.4.4 Skin effect

In many cases, skin effect correction will not be necessary for the enclosure. However, it should be checked by use of factors obtained in the curves shown in Figure A.1, Figure A.2, and Figure A.3.

A.4.5 Loss factor

A.4.5.1 Continuous circular enclosures

The voltage induced in a circular enclosure by the current in the conductor that it surrounds causes a longitudinal current flow in the continuous enclosure. This current returns through the enclosures of adjacent phases. The enclosure longitudinal current is very nearly equal in magnitude to the conductor current, lagging by somewhat less than 180 degrees. Due to the opposite polarities of conductor and enclosure currents, the magnetic flux is mainly contained within the enclosure. The sum of the conductor and enclosure current is equal to the effective magnetizing current, which establishes the magnetic field external to the enclosure. The effective magnetizing current will vary from 2% through 10% of the conductor current. For this reason and because the magnetizing and enclosure currents are very nearly 90 degrees apart, for most installations the magnitude of the enclosure current will equal that of the conductor current.

As shown in Niemoller [B28], neglecting the impedance of cross connections, the current I_e in the continuous enclosure is related to the conductor current I as shown in Equation (A.12):

$$\frac{I_e}{I} = \cos \left[\cot^{-1} \left(4.61 \iota^2 \log \frac{2S}{D} \right) \right] \quad (\text{A.12})$$

where

ι^2 = enclosure factor,

S/D = reciprocal of the spacing factor.

If ι^2 is greater than 7, the value of I_e/I as calculated from Equation (A.12) will fall between 0.995 and 1.000. However, the actual value of I_e/I will be somewhat less due to the impedance of cross connections. If it is assumed that the impedance of cross connection is equivalent to the impedance of an enclosure of length S , use Equation (A.13):

$$\frac{I_e}{I} = \kappa_c \cos \left[\cot^{-1} \left(4.61 \iota^2 \log \frac{2S}{D} \right) \right] \quad (\text{A.13})$$

where κ_c is derived empirically as shown in Equation (A.14):

$$\kappa_c = \frac{L}{L+S} + \left(1 - \frac{L}{L+S}\right) \left(\frac{D}{S}\right) = \left(\frac{L+D}{L+S}\right) \quad (\text{A.14})$$

where

- L = length of bus enclosure,
- D = enclosure mean diameter,
- S = spacing of conductor center lines,

and L , D , and S should be expressed in the same units.

Under such conditions, the loss factor K for use in Equation (A.8) is given in the following:

- a) For the total loss in the three enclosures of a balanced three-phase run:

$$K = 3 \left(\frac{I_e}{I}\right)^2$$

- b) For the total loss in the three enclosures of an unbalanced three-phase run where the current in one conductor is I and $I/\sqrt{3}$ in the other two:

$$K = \frac{5}{3} \left(\frac{I_e}{I}\right)^2$$

- c) For the total loss in the two enclosures of a single-phase power tap:

$$K = \frac{2}{3} \left(\frac{I_e}{I}\right)^2$$

A.4.5.2 Noncontinuous circular enclosures

Since there is no external return path, the voltage induced in a noncontinuous enclosure by the current in the conductor that it surrounds cannot cause longitudinal current flow; however, nonuniform voltages are induced in the adjacent enclosures. These nonuniform voltages cause local current flow in each insulated enclosure section.

The enclosure currents flow in nonuniform patterns. The magnitude and phase angle of the current density in the longitudinal direction are functions of the angular position of the enclosure filaments. The flow pattern depends on the magnitude and phase angle of the conductor currents, the spacing factor D/S , and the enclosure factor τ^2 .

The loss per unit length of enclosure is evaluated by integrating, over the circumference that constitutes its cross section, the I^2R losses produced in all the elementary filaments. The result of this integration is expressed as the loss factor K to be used with Equation (A.8).

The value of K depends principally on the parameter D/S and to a lesser extent on the parameter τ^2 . The extreme values of τ^2 expected in practical installations are 5 and 55. The K versus D/S curves at $\tau^2 = 10$ and for different specified conditions are plotted in Figure A.7. The curves are based on formulas given in Dwight [B25] and Conangla and White [B24]. The loss factors shown in Figure A.7 may be used for installations when the conductor center lines are parallel and coplanar, and the enclosure factor τ^2 lies between 5 and 55.

Curves A, B, and C of Figure A.7 cover three-phase installation. For these curves, the K factor involves the total loss in all three enclosures and is related to the full-line current I .

Curve A is applicable to a three-phase run carrying balanced currents. Curves B and C are applicable to that portion of a three-phase installation falling between single-phase taps, where one conductor carries the full-line current I and the other two conductors carry the phase current $I/\sqrt{3}$. Curve B applies when one of the outside conductors carries the line current I ; Curve C applies when the center conductor carries the line current I .

Curve D of Figure A.7 is applicable to a two-conductor, single-phase tap and involves the total loss in both enclosures. For the convenience of grouping calculations as shown in the sample solution included in this guide, the K factors of Curve D are also related to the full-line current I . To relate Curve D to the actual single-phase current, the K factor must be multiplied by three.

Percent deviation of K versus D/S curves are also plotted in Figure A.8. Curve E is applicable to balanced three-phase installations and is used in conjunction with Curve A. The curves show the percent that the value of K at $\tau^2 = 5$ and 55 deviates from the value of K at $\tau^2 = 10$. Deviation of K at other intermediate values of τ^2 can be approximated by interpolation. Curve E can also be used in conjunction with Curves B and D with only slight error. Curve F should be used in conjunction with Curve C.

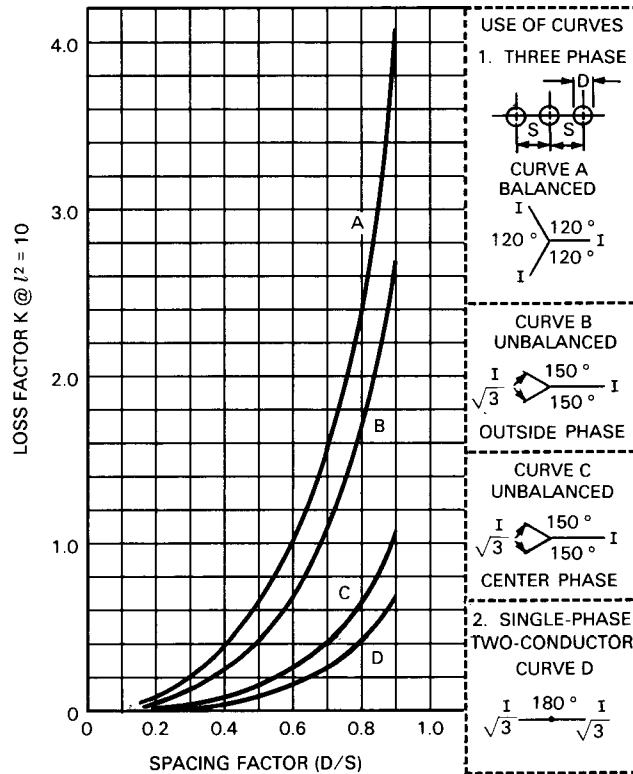

Figure A.7—Loss factors for noncontinuous bus enclosure

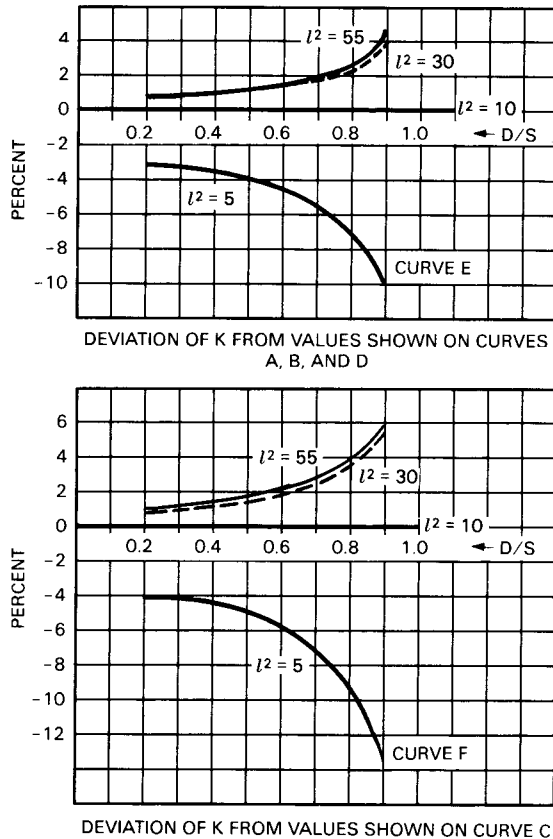

Figure A.8—Loss factor deviation curves for noncontinuous bus enclosures

A.5 Power consumption of cooling equipment

The power consumed by blowers, fans, circulating pumps, etc., used for force-cooling the buses should be considered a power loss in the evaluation of designs. Power requirements for cooling equipment should be stipulated by the manufacturer.

A.6 Sample solutions

An isolated-phase bus installation is considered extending from the terminals of the 330 MVA, 20 kV generator to three single-phase, step-up transformers. The overall dimensions of the layout (Figure A.6) are given, as follows:

Conductor:

Round-tube 61% conductivity aluminum

Main three-phase bus:

368 mm (14.5 in) outside diameter, 12 mm (0.47 in) wall

Transformer taps:

216 mm (8.5 in) outside diameter, 9.5 mm (0.375 in) wall

Enclosure:

Round 57% conductivity aluminum
749 mm (29.5 in) outside diameter, 6.4 (0.25 in) mm wall

Phase spacing:

$S = 1041$ mm (41 in)

Construction:

Noncontinuous enclosure

Ratings:

Self-cooled, based on conductor 65 °C rise over 40 °C ambient
Main bus, 10 kA; taps, 6 kA

Power frequency:

60 Hz

Losses are to be calculated assuming operation at the full-load rating of the generator, 9500 A, and a 40 °C ambient temperature.

A.6.1 Percent loading**Main conductors:**

$$\frac{9500}{10\,000} \cdot 100 = 95\%$$

Single-phase taps:

$$\frac{9500/\sqrt{3}}{6000} \cdot 100 = 91.4\%$$

A.6.2 Estimated operating temperatures

For conductors, Equation (A.2) is used.

Main conductors:

$$\text{Temperature} = 40 + [(0.95)^{1.7} \cdot 65] = 99.6 \text{ °C}$$

Single-phase taps:

$$\text{Temperature} = 40 + [(0.914)^{1.7} \cdot 65] = 95.8 \text{ °C}$$

For enclosures, Equation (A.9) is used.

Main conductors: enclosure temperature

$$\text{Temperature} = 40 + [(0.95)^{1.7} \cdot 40] = 76.7 \text{ °C}$$

Single-phase taps: enclosure temperature

$$\text{Temperature} = 40 + [(0.914)^{1.7} \cdot 40] = 74.3 \text{ °C}$$

A.6.3 DC resistances

Equation (A.11a) is used.

Main conductor:

$$d = 14.5 \text{ in}; t = 0.47 \text{ in}; \gamma = 61 \text{ (at } 20 \text{ }^\circ\text{C)}$$

$$\begin{aligned} R_{dc(20)} &= \frac{259}{(14.5 - 0.47) \cdot 0.47 \cdot 61} \\ &= 0.644 \text{ } \mu\Omega/\text{ft at } 20 \text{ }^\circ\text{C} \end{aligned}$$

Single-phase taps:

$$d = 8.5 \text{ in}; t = 0.375 \text{ in}; \gamma = 61 \text{ (at } 20 \text{ }^\circ\text{C)}$$

$$\begin{aligned} R_{dc(20)} &= \frac{259}{(8.5 - 0.375) \cdot 0.375 \cdot 61} \\ &= 1.394 \text{ } \mu\Omega/\text{ft at } 20 \text{ }^\circ\text{C} \end{aligned}$$

Enclosure:

$$D = 29.5 \text{ in}; t = 0.25 \text{ in}; \gamma = 57 \text{ (at } 20 \text{ }^\circ\text{C)}$$

$$\begin{aligned} R_{dc(20)} &= \frac{259}{(29.5 - 0.25) \cdot 0.25 \cdot 57} \\ &= 0.621 \text{ } \mu\Omega/\text{ft at } 20 \text{ }^\circ\text{C} \end{aligned}$$

A.6.4 Corrections for operating temperature

Equation (A.5) is used.

Main conductor:

$$\text{Temperature} = 99.6 \text{ }^\circ\text{C}; 61\% \text{ conductivity}$$

$$\begin{aligned} R_{dc(99.6)} &= R_{dc(20)} [1 + 0.000066 \cdot 61 (99.6 - 20)] \\ &= 0.644 (1.320) \\ &= 0.850 \text{ } \mu\Omega/\text{ft at } 99.6 \text{ }^\circ\text{C} \end{aligned}$$

Single-phase taps:

$$\text{Temperature} = 95.9 \text{ }^\circ\text{C}; 61\% \text{ conductivity}$$

$$R_{dc(95.9)} = R_{dc(20)} [1 + 0.000066 \cdot 61 (95.9 - 20)]$$

$$= 1.394 (1.306)$$

$$= 1.821 \mu\Omega/\text{ft at } 95.9 \text{ }^\circ\text{C}$$

Enclosures:

Average temperature = 76.7 °C; 57% conductivity

$$R_{dc(76.7)} = R_{dc(20)} [1 + 0.000066 \cdot 57(76.7 - 20)]$$

$$= 0.621 (1.213)$$

$$= 0.753 \mu\Omega/\text{ft at } 76.7 \text{ }^\circ\text{C}$$

A.6.5 Skin effect correction

Main conductor:

$$\frac{t}{d} = \frac{0.47}{14.5} = 0.0324; \sqrt{\frac{f \cdot 10^3}{R_{dc}}} = \sqrt{\frac{60 \cdot 10^3}{0.850}} = 265.5$$

From Figure A.1:

$$\frac{R_{ac}}{R_{dc}} = 1.08$$

$$R_{ac} = 1.08 \cdot R_{dc(99.6)}$$

$$= 1.08 \cdot 0.850$$

$$= 0.918 \mu\Omega/\text{ft at } 99.6 \text{ }^\circ\text{C}$$

Single-phase taps:

$$\frac{t}{d} = \frac{0.375}{8.5} = 0.441; \sqrt{\frac{f \cdot 10^3}{R_{dc}}} = \sqrt{\frac{60 \cdot 10^3}{1.821}} = 181.5$$

From Figure A.1:

$$\frac{R_{ac}}{R_{dc}} = 1.04$$

$$R_{ac} = 1.04 \cdot R_{dc(95.9)}$$

$$= 1.04 \cdot 1.821$$

$$= 1.893 \mu\Omega/\text{ft at } 95.9 \text{ }^\circ\text{C}$$

Enclosures:

$$\frac{t}{d} = \frac{0.25}{29.5} = 0.0085; \sqrt{\frac{f \cdot 10^3}{R_{dc}}} = \sqrt{\frac{60 \cdot 10^3}{0.753}} = 282.3$$

From Figure A.1:

$$\frac{R_{ac}}{R_{dc}} = 1.005$$

$$\begin{aligned} R_{ac} &= 1.005 \cdot R_{dc(76.7)} \\ &= 1.005 \cdot 0.753 \\ &= 0.757 \mu\Omega/\text{ft at } 76.7 \text{ }^\circ\text{C} \end{aligned}$$

A.6.6 Conductor loss

For a summary of conductor losses for the conductors in the previous examples, please see Table A.2.

Table A.2—Conductor losses

Portion	$(KA)^2$	R_{ac}	Length ^a	=	Watts
I_a	$(9.5)^2$	0.918	98.3	=	8 144
I_{a-b}	$(9.5/\sqrt{3})^2$	1.893	(23.4 + 20.0)	=	2 472
I_b	$(9.5)^2$	0.918	101.7	=	8 426
I_{b-c}	$(9.5/\sqrt{3})^2$	1.893	(46.6 + 16.6)	=	3 599
I_c	$(9.5)^2$	0.918	131.7	=	10 911
I_{c-a}	$(9.5/\sqrt{3})^2$	1.893	(43.2 + 86.8)	=	7 403
Total conductor loss; P_c : (watts)				=	40 955

^aSee Figure A.6

A.6.7 Enclosure loss

Enclosure factor: Equation (A.7) is used.

$$t^2 = \frac{0.1915 \cdot 60}{0.757} = 15.18 \text{ (which lies between 5 and 55)}$$

Spacing factor:

Three-conductor runs and single-phase taps (see Figure A.6):

$$\frac{D}{S} = (29.5 - 0.25) \div 41 = 0.713$$

Two-conductor, single-phase run (see Figure A.6):

$$\frac{D}{S} = (29.5 - 0.25) \div (2 \cdot 41) = 0.357$$

A.6.8 Continuous enclosure construction

Cross-connection factor: Equation (A.14) is used.

Three-conductor, balanced-current run:

Length = 100 ft, spacing = 41 in, $D/S = 0.713$

$$\begin{aligned} \kappa_c &= \frac{100 \cdot 12}{(100 \cdot 12) + 41} + \left[\left(1 - \frac{1200}{1241} \right) \cdot 0.713 \right] \\ &= 0.967 + [(0.033) (0.713)] = 0.991 \end{aligned}$$

Three-conductor, unbalanced-current run:

Length = 30 ft, spacing = 41 in, $D/S = 0.713$

$$\begin{aligned} \kappa_c &= \frac{30 \cdot 12}{(30 \cdot 12) + 41} + \left[\left(1 - \frac{360}{401} \right) \cdot 0.713 \right] \\ &= 0.898 + [(0.102) (0.713)] = 0.971 \end{aligned}$$

Two-conductor, single-phase run:

Length = 30 ft, spacing = $2 \cdot 41 = 82$ in, $D/S = 0.357$

$$\begin{aligned} \kappa_c &= \frac{30 \cdot 12}{(30 \cdot 12) + 82} + \left[\left(1 - \frac{360}{442} \right) \cdot 0.357 \right] \\ &= 0.814 + [(0.186) (0.357)] = 0.880 \end{aligned}$$

Two-conductor, single-phase taps:

Length = $3 \cdot 20 = 60$ ft, spacing = 41 in, $D/S = 0.713$

$$\begin{aligned} \kappa_c &= \frac{60 \cdot 12}{(60 \cdot 12) + 41} + \left[\left(1 - \frac{720}{761} \right) \cdot 0.713 \right] \\ &= 0.946 + [(0.054) (0.713)] = 0.985 \end{aligned}$$

Loss factor:

Since $\tau^2 = 15.18$, from Equation (A.12):

$$\cos \left[\cot^{-1} \left(4.61 \tau^2 \log 2 \frac{S}{D} \right) \right] = 1$$

and

$$\frac{I_e}{I} = \kappa_c$$

Three-conductor, balanced-current run:

$$K = 3 \left(\frac{I_e}{I} \right)^2 = 3(0.991)^2 = 2.946$$

Three-conductor, unbalanced-current run:

$$K = \frac{5}{3} \left(\frac{I_e}{I} \right)^2 = \frac{5}{3}(0.971)^2 = 1.571$$

Two-conductor, single-phase run:

$$K = \frac{2}{3} \left(\frac{I_e}{I} \right)^2 = \frac{2}{3}(0.880)^2 = 0.516$$

Two-conductor, single-phase taps:

$$K = \frac{2}{3} \left(\frac{I_e}{I} \right)^2 = \frac{2}{3}(0.985)^2 = 0.647$$

For each portion, the enclosure loss is KI^2R_eL .

$$I^2R_e = (9.5)^2 \cdot 0.757 = 68.3 \text{ W/ft}$$

For a summary of results for enclosure losses in isolated-phase bus with continuous enclosures, see Table A.3.

Table A.3—Summary of enclosure losses for continuous enclosures

Portion	I^2R_{ac}	K	Length	=	Watts
Three-conductor, balanced	68.3	2.946	100	=	20 121
Three conductor, unbalanced	68.3	1.571	30	=	3 219
Two-conductor, single-phase	68.3	0.516	30	=	1 057
Single-phase taps	68.3	0.647	60	=	2 651
Total conductor loss; P_c : (watts)				=	27 048
Total operating loss at 9.5 kA (with continuous enclosure construction): $P_{\text{total}} = P_c + P_e = 40\,955 + 27\,048 = 68\,003 \text{ W}$					

A.6.9 Noncontinuous enclosure construction

Equation (A.7) is used, with K to suit, as follows:

Three-conductor, balanced-current run:

Length = 100 ft; $D/S = 0.713$. Figure A.7, Curve A:

$K = 1.65$; Figure A.8, Curve E: deviation = 1%, $\therefore K = 1.65 (1.01) = 1.67$

(Factor K covers total loss in three enclosures.)

Three-conductor, unbalanced-current run with line current in outside conductor:

Length = 30 ft; $D/S = 0.713$. Figure A.7, Curve B:

$K = 1.125$; Figure A.8, Curve E: deviation = 1%, $\therefore K = 1.125 (1.01) = 1.14$

(Factor K covers total loss in three enclosures.)

Two-conductor, single-phase run:

Length = 30 ft; $D/S = 0.357$. Figure A.7, Curve D:

$K = 0.025$; Figure A.8, Curve E: deviation = less than 1%, can be ignored

(Factor K covers total loss in two enclosures.)

Two-conductor, single-phase taps:

Length = $3 \cdot 20 = 60$ ft; $D/S = 0.713$. Figure A.7, Curve D:

$K = 0.28$; Figure A.8, Curve E: deviation = 1%, $\therefore K = 0.28 (1.01) = 0.283$

(Factor K covers total loss in two enclosures.)

For each portion, the enclosure loss is $P_e = KI^2R_eL$.

$$I^2R_e = 0.757 \cdot (9.5)^2 = 68.3 \text{ W/ft}$$

For a summary of results for enclosure losses in isolated-phase bus with noncontinuous enclosures, see Table A.4.

Table A.4—Summary of enclosure losses for noncontinuous enclosures

Portion	I^2R_{ac}	K	Length	=	Watts
Three-conductor, balanced	68.3	1.67	100	=	11 406
Three conductor, unbalanced	68.3	1.14	30	=	2 336
Two-conductor, single-phase	68.3	0.025	30	=	51
Single-phase taps	68.3	0.283	60	=	1 160
Total conductor loss; P_c : (watts)				=	14 953
Force-cooling loss: in this case, there is none.					
Total operating loss at 9.5 kA (with continuous enclosure construction)					
$P_{\text{total}} = P_c + P_e = 40\,955 + 14\,953 = 55\,908 \text{ W}$					

A.7 Structural steel losses

This clause is included to point out additional losses that could occur if due consideration is not given to the relationship of the bus to nearby structural members and piping. The data will assist the user in determining where corrective measures are required or in estimating the magnitude of losses in existing installations. If a troublesome condition is suspected during the design stage, it is recommended that corrective measures be adopted at that time. Losses in structures external to the bus installation should be excluded from loss calculations used in economic evaluations, since such heat losses cannot be predicted with any great accuracy.

Losses in structural steel near conductors carrying heavy currents are caused by the following:

- a) Circulating currents flowing in closed metallic loops that link the magnetic flux associated with the conductor currents. These loops usually include structural members running in a direction parallel to the longitudinal axis of the bus run. The circulating current loss is avoided by breaking the electrical continuity of the loops, by physical gaps, or with insulation inserted at some convenient point.
- b) Hysteresis and eddy currents due to flux contained in magnetic material members. Steel supports or pipes in close proximity, and running in a direction normal to the longitudinal axis of the bus run, are likely to heat up due to this effect. The magnetic flux in such members is minimized by using low-resistance, short-circuited bands at locations where they pass over the main conductors.

The supporting structure furnished as part of an isolated-phase bus installation should include insulated joints and short-circuited bands in the proper locations to avoid or minimize losses due to these effects. With such measures, the losses in the supporting structure are negligible and should not be considered in overall loss evaluation.

The continuous enclosure construction constitutes a means for minimizing losses in nearby structures. Other recognized means are the opening of closed conductive loops to avoid circulating currents, the installation of short-circuited bands around steel members to reduce the magnetic flux in them, and the interposition of amortisseur grids or plates to shield the structural members from the flux produced by the conductor currents.

Annex B

(informative)

Bibliography

The following pertinent standards are suggested for further study and better understanding of this standard:

[B1] ANSI C84.1-1995 (Reaff 2001), American National Standard for Electric Power Systems and Equipment—Voltage Ratings (60 Hz).

[B2] ANSI Z535.4-2002, Product Safety Sign and Label.

[B3] ANSI C37.06-2000, American National Standard AC High-Voltage Circuit Breakers Rated on Symmetrical Current Basis—Preferred Ratings and Related Required Capabilities.

[B4] ASTM B117-2003, Standard Practice for Operating Salt Spray (Fog) Apparatus.

[B5] ASTM D714-2002, Standard Test Method for Evaluating Degree of Blistering of Paints.

[B6] ASTM D1654-1992 (Reaff 2000), Standard Test Method for Evaluation of Painted or Coated Specimens Subjected to Corrosive Environments.

[B7] ASTM D2303-1997, Standard Test Methods for Liquid-Containment, Inclined-Plane Tracking and Erosion of Insulating Materials.

[B8] Federal Specification No. A-A-1492B, Tape, Gummed, Paper, Reinforced and Plain for Sealing and Securing.¹⁴

[B9] IEEE 100, *The Authoritative Dictionary of IEEE Standards Terms*, Seventh Edition.¹⁵

[B10] IEEE Std 142™-1991, IEEE Recommended Practice for Grounding of Industrial and Commercial Power Systems—(*IEEE Green Book*).

[B11] IEEE Std C37.11-1997, IEEE Standard Requirements for Electrical Control for AC High Voltage Circuit Breakers Rated on a Symmetrical Current Basis.

[B12] IEEE Std C37.13™-1990 (Reaff 1995), IEEE Standard for Low-Voltage AC Power Circuit Breakers Used in Enclosures.

[B13] IEEE Std C37.14-2002, IEEE Standard for Low-Voltage DC Power Circuit Breakers Used in Enclosures.

[B14] IEEE Std C37.20.1-2002, IEEE Standard for Metal-Enclosed Low-Voltage Power Circuit Breaker Switchgear.

[B15] IEEE Std C37.20.3™-2001, IEEE Standard for Metal-Enclosed Interrupter Switchgear.

¹⁴Federal Specifications can be obtained from the Standardization Division, Federal Supply Service, General Services Administration, Washington, DC 20406 (<http://www.gasa.gov/>).

¹⁵The IEEE standards or products referred to in Annex B are trademarks owned by the Institute of Electrical and Electronics Engineers, Incorporated.

[B16] IEEE Std C37.20.4™-2001, IEEE Standard for Indoor AC Switches (1 kV–38 kV) for Use in Metal Enclosed Switchgear.

[B17] IEEE Std C37.21™-1985, IEEE Standard for Control Switchboards.

[B18] IEEE Std C37.26™-1972 (Reaff 1996), IEEE Guide for Methods of Power-Factor Measurement for Low-Voltage Inductive Test Circuits.

[B19] IEEE Std C57.13™-1993, IEEE Standard Requirements for Instrument Transformers.¹⁶

[B20] NEMA 260-1996, Safety Labels for Padmounted Switchgear and Transformers Sited in Public Areas.

[B21] NEMA LI 1-1998, Industrial Laminated Thermosetting Products .

[B22] NEMA WC 71-1999/ICEA S-95-659-1999, Standard for Nonshielded Cables Rated 2001–5000 Volts for Use in the Distribution of Electric Energy.

[B23] UL 486A-1997, Wire Connectors.

Recommended Reading

It is recommended that individuals responsible for the layout of isolated-phase bus study the following materials, particularly Swerdlow and Buchta [B29], to circumvent possible troublesome conditions in the early stages of design.

[B24] Conangla, A. and White, H. F., “Isolated-Phase Bus Enclosure Loss Factors,” *IEEE Transactions on Power Apparatus and Systems*, vol. PAS-87, pp. 1622–1628, July 1968.

[B25] Dwight, H. B., *Electrical Coils and Conductors*, New York: McGraw Hill, 1945.

[B26] Dwight, H. B., “Some Proximity Effect Formulas for Bus Enclosures,” *IEEE Transactions on Power Apparatus and Systems*, vol. PAS-83, pp. 1167–1172, Dec. 1964.

[B27] Elgar, E. C, Rehder, R. H., and Swerdlow, N., “Measured Losses in Isolated-Phase Bus and Comparison with Calculated Values,” *IEEE Transactions on Power Apparatus and Systems*, vol. PAS-87, pp. 1724–1730, Aug. 1968.

[B28] Nemoller, A. B., “Isolated-Phase Bus Enclosure Currents,” *IEEE Transactions on Power Apparatus and Systems*, vol. PAS-87, pp. 1714–1718, Aug. 1968.

[B29] Swerdlow, N., and Buchta, M. A, “Practical Solutions of Inductive Heating Problems Resulting from High-Current Buses,” *AIEE Transactions on Power Apparatus and Systems*, vol. 78, part IIIB, pp. 1736–1746, 1959 (Feb. 1960 section).

NOTE—Swerdlow and Buchta give data for estimating the average temperature rise due to hysteresis and eddy currents in steel members in proximity to unenclosed buses carrying large currents. They also give data on the effects of shielding devices and on methods for determining power losses by determination of the energy loss from the steel by radiation and convection. Although primarily concerned with unenclosed buses, they include rules for application of the data to isolated-phase buses.

¹⁶IEEE Std C57.13-1993 has been withdrawn; however copies can be obtained from Global Engineering, 15 Inverness Way East, Englewood, CO 801212-5704, USA, tel +1 303 792-2181 (<http://global.ihs.com/>).